

# ZONING ORDINANCE

## FOR THE CITY OF ERIE

City of Erie Ordinance Number 80-2005



**CITY OF ERIE – Bureau of Code Enforcement**  
**626 State Street – Room 407**  
**Erie, Pennsylvania 16501**

**As amended:**

- Rev. A** July 5, 2006 – Map Revision: (18) 5012-100 & 102 rezoned to C-2 General Commercial
- Rev. B** January 3, 2007 – Map Revision: (14) 1023-204 rezoned to M-1 Light Manufacturing
- Rev. C** February 28, 2007 – Text Revision: Lot Area Per Family in C-3 Zoning District
- Rev. D** August 17, 2007 – Text Revision: Definition of Commercial Recreation and addition to Heavy Manufacturing District  
August 5, 2009 – Text Revision: Amending Definition of Dormitory, Revising Parking Requirements for Dormitories, Enacting Regulations for Massage Therapist, and Amending Communication Towers / Antennas Criteria
- Rev. E** January 21, 2010 & February 3, 2010 - Enacting Regulations for Wind Energy Conversion Systems, Small Wind Energy Systems, Commercial/Industrial Wind Energy Systems, Solar Collection System  
and Urban Solar Farm - May 2012 - Map Revision

The preparation of this ordinance and map was financed in part through a Land Use Planning and Technical Assistance Grant from the Department of Community and Economic Development, as administered by the Governor's Center for Local Government Services, Pennsylvania Department of Community and Economic Development.

## TABLE OF CONTENTS

			<u>Page</u>
<b>ARTICLE 1</b>		<b>GENERAL PROVISIONS</b>	
Section	101	Title	1
	102	Effective Date	1
	103	Compliance	1
	104	Severability	1
	105	Repeal	1
	106	Authority	1
	107	Purpose and Provisions	1
	108	Statement of Community Development Objectives	2
	109	Fees	2
 <b>ARTICLE 2</b>		 <b>DISTRICT REGULATIONS</b>	
Section	201	Zoning Map	3
	202	Zoning Districts	3
	203	District Boundaries	5
	204	Permitted and Conditional Uses and Special Exceptions	5
	205	Lot, Yard and Height Requirements	23
	206	Manufacturing Park (I.P.) District Regulations	30
 <b>ARTICLE 3</b>		 <b>GENERAL REGULATIONS</b>	
Section	301	Nonconforming Uses and Nonconforming Structures	40
	302	Off-Street Parking	41
	303	Signs	43
	304	Temporary Structures and Storage	46
	305	Conditional Uses, Special Exceptions and Special Regulation Criteria	47
	306	Conditional Uses - Waterfront Districts	65
	307	Screening Requirements	72
	308	Planned Residential Development	72
 <b>ARTICLE 4</b>		 <b>ADMINISTRATION AND ENFORCEMENT</b>	
Section	401	Zoning Officer	83
	402	Zoning Certificates	83
	403	Violations and Penalties	83
	404	Method of Appeal	85
	405	Amendments	85
	406	Procedure to Obtain Preliminary Opinion	87

**ARTICLE 5****ZONING HEARING BOARD**

Section	501	Creation	89
	502	Appointment	89
	503	Removal of Members	89
	504	Organization of Board	89
	505	Expenditures for Services	89
	506	Legal Counsel	89
	507	Hearings	89
	508	Board Functions	86
	509	Parties Appellant Before Board	88
	510	Time Limitations; Persons Aggrieved	89
	511	Stay of Proceedings	89

**ARTICLE 6****DEFINITIONS****95****ARTICLE 7****HISTORIC RESOURCES PROTECTION**

Section	701	Statement of Intent	117
	702	Overview of Provisions	117
	703	Zoning Overlay Concept	117
	704	Identified Historic Resources	118
	705	Provisions Which Apply to All Structures Existing or Proposed Within the Historic Overlay District	118
	706	Application Procedures	119
	707	Standards and Considerations for Architectural Review	119
	708	Violations, Penalties, and Enforcement	121

# ZONING ORDINANCE

## CITY OF ERIE, PENNSYLVANIA

**BE IT ENACTED** by the Council of the City of Erie, Pennsylvania, that in the interest of promoting the public health, safety, order, convenience, prosperity or general welfare of the community embraced within the territorial limits of the City of Erie, the following articles and sections be, and the same hereby are, enacted into law:

### ARTICLE 1 - GENERAL PROVISIONS

**101 TITLE:** The official title of this Ordinance is: "Zoning Ordinance, City of Erie, Pennsylvania."

**102 EFFECTIVE DATE:** This Ordinance shall become effective twenty (20) days after final passage and approval by the Mayor.

**103 COMPLIANCE:** No structure shall be located, erected, constructed, reconstructed, moved, converted, or enlarged; nor shall any structure or land be used or be designed to be used, except in full compliance with all the provisions of this Ordinance and after the lawful issuance of all permits and certificates required by this Ordinance. Terms shall generally be interpreted as follows: The present tense shall include the future, singular number shall include the plural and the plural the singular. The word "shall" is always mandatory and the word "may" is permissive. The masculine shall include the feminine. The word "sale" includes "rental".

**104 SEVERABILITY:** The provisions of this Ordinance shall be severable, and, if any of its provisions shall be unconstitutional, the decision so holding shall not be construed to affect the validity of any of the remaining provisions of this Ordinance. It is hereby declared as the legislative intent that this Ordinance would have been adopted had such unconstitutional provisions not been included therein.

**105 REPEAL:** That all ordinances or part thereof conflicting herewith be and the same are hereby repealed.

**106 AUTHORITY:** This Ordinance is adopted pursuant to the powers granted to the City by Section 601 of the Pennsylvania Municipalities Planning Code. In their interpretation and application, the provisions of this Zoning Ordinance shall be held to be the minimum requirements adopted for the promotion of the public health, safety, morals and/or general welfare. Wherever the requirements of this Zoning Ordinance are at variance with the requirements of any lawfully adopted rules, regulations or ordinances applicable to the City or with one another, the more restrictive upon uses, structures or other development, or that imposing the higher standards shall be controlling.

**107 PURPOSE AND PROVISIONS:** The purposes and provisions of this Ordinance are those as set forth by Sections 603, 603.1, and 604 of the Pennsylvania Municipalities Planning Code.

**108 STATEMENT OF COMMUNITY DEVELOPMENT OBJECTIVES:** This statement sets forth the policy goals of this Ordinance.

- 108.10** To set aside land for residential, commercial, manufacturing and waterfront uses in Erie City along with appropriate transitional districts so developed land in Erie can exist in a compatible and harmonious way.
- 108.20** To acknowledge the important roles that colleges, universities, hospitals and similar institutions play in Erie's overall well-being and to reasonably accommodate such uses.
- 108.30** To preserve, protect and improve residential neighborhoods.
- 108.40** To provide land for manufacturing development and to protect manufacturing areas.
- 108.50** To provide land for commercial development and to protect commercial areas.
- 108.60** To protect valuable transportation resources and corridors.
- 108.70** To support and promote the City's urban renewal and redevelopment programs.
- 108.80** To support housing for Erie's citizens who are mentally or physically handicapped.
- 108.90** To require a high quality of development in Erie City. Though this Ordinance makes every effort to accommodate a great variety of uses and development, it insists that any development adhere to this and other ordinances of the City which set forth standards to assure quality development.
- 108.11** To provide for the recognition and protection of historic areas within the City of Erie.
- 108.12** To promote the constant renewal of Erie City without encouraging incompatible land uses.
- 108.13** To welcome and encourage both development and re-development within the City of Erie.

**109 Fees** Fees are determined by resolution of City Council.

## ARTICLE 2 - DISTRICT REGULATIONS

**201 ZONING MAP:** A map entitled "Zoning Map, City of Erie, Pennsylvania" is hereby adopted as part of this Ordinance. The Zoning Map shall be kept on file available for examination at the Office of Economic and Community Development and Zoning. Copies of the Zoning Map, together with the Zoning Ordinance, shall be made available to the general public by the City at a reasonable fee to be determined by resolution of City Council .

**202 ZONING DISTRICTS:** The City is divided into the districts stated in this Ordinance as shown by the district boundaries on the Zoning Map. The districts are:

**202.10 RESIDENTIAL DISTRICTS:** Districts designated for residential use are for dwellings and the uses normally associated with residential neighborhoods. Such uses include schools, churches and parks. The specific purpose of each of the residential districts are as follows:

**202.11 R-1 Low Density Residential Districts** are for single-family residential developments of relatively low density.

**202.12 R-1A Low Density Residential Districts** are for single-family residential developments of relatively low density in areas which contain narrow lots..

**202.13 R-2 Medium Density Residential Districts** are for one to four family residential developments of low to moderate density.

**202.14 R-3 High Density Residential Districts** are for multiple-family residential developments on valuable centrally located property or property where good access, public utilities, and community facilities warrant a higher density of population. Higher densities would be accommodated primarily through apartments or other multiple family dwellings.

### **202.20 RESIDENTIAL LIMITED BUSINESS DISTRICTS:**

This district is designated for medium density residential developments, limited local retail commercial activities, and many other limited commercial activities, especially those associated with the owner's home. Also, several public and semi-public uses are included. This designation broadens the use of properties on the periphery of intense uses areas or along major transportation corridors while seeking to minimize incompatibility problems with existing uses. The specific purpose of the Residential Limited Commercial District is as follows:

**202.21 RLB Residential Limited Commercial District** is primarily for residential uses, home occupations, and limited commercial uses, generally located in the developed areas along major thoroughfares or adjacent to Commercial or Manufacturing Districts.

**202.30 COMMERCIAL DISTRICTS:** Districts designated for commercial use are more restrictive in outlying residential areas. Compact district for commercial uses can be served better with fire protection, police protection and other public services than scattered individual uses or mixed development. Most manufacturing uses are excluded in order to minimize truck and rail traffic especially in primarily residential areas. However, research laboratories and certain light manufacturing uses are permitted if they are of such a nature that they do not cause any hazards and if they meet specific requirements set forth in this Ordinance. The specific purpose of each of the commercial districts are as follows:

**202.31** C-1 Local Commercial Districts are for small scale retail shopping facilities, and other small scale business uses in locations where they can offer goods and services to nearby residents conveniently without adversely affecting residential properties.

**202.32** C-2 General Commercial Districts are for all retail establishments without a size restriction, which normally occur within shopping centers. Also included in this district are automobile-oriented businesses and services and other corporate and commercial activities.

**202.33** C-3 Central Commercial District is for major shopping facilities, offices, entertainment facilities and related uses which serve the entire Erie area. The primary purpose of this district is to satisfy the unique needs and to promote the sound development of the Central Commercial District. In addition, this district may be applied to other large land areas to permit comprehensive commercial development.

**202.34** C-4 Traditional Neighborhood Commercial, while the uses are very similar to the C-1, Local Business District, the differing factor is the character of the physical environment. This district has the high density building character of the C-3 district while providing services and storefronts catering to the neighborhood.

**202.40 MANUFACTURING DISTRICTS:** Districts designated for industry provide space for the continued development of Erie's manufacturing base. Development standards, parking specifications, and yard regulations are set forth in the Ordinance to assure manufacturing development compatible with adjacent uses. The specific purposes of the manufacturing districts are as follows:

**202.41** M-1 Light Manufacturing Districts are for the development of very high standard precision industries in a protected environment.

**202.42** M-2 Heavy Manufacturing Districts are for a wider range of manufacturing activities under conditions and standards which protect adjacent properties from adverse or objectionable influences.

**202.43** I-P Industrial Park Districts are created as an area to be developed exclusively for manufacturing activity but with more restrictions than an Manufacturing designation. These Districts encourage the use of manufacturing park development. Such development treats a



large expanse of land as an manufacturing subdivision by planning, construction, servicing and maintaining it in a manner that will make resourceful use of the land, increase the compatibility and attractiveness of these uses to each other, and protect the City's advantage in attracting industry. All requirements in this Ordinance shall govern for the Manufacturing Park designation except where specific exceptions or additions are provided.

**202.50 WATERFRONT DISTRICTS:** The Waterfront District is to provide a framework to guide and control the development of the Erie Bayfront. This district is intended to coordinate future public and private improvements in a mixed land use concept. The specific purpose of each of the Waterfront districts is as follows:

**202.51** W-C and W-C2 (Waterfront Commercial Districts) shall be designed for residential, commercial, recreational and historical uses.

**202.52** W-M (Waterfront Manufacturing District) shall be designed for industry that requires waterfront or waterfront-related uses.

**202.53** W-R (Waterfront Residential District) shall be designed single-, two- and multiple-family dwellings of high density on valuable properties or property where good access, public utilities and common facilities warrant a higher density of population.

**202.54** W-C3 shall be designed for commercial, cultural and recreational uses.

**203 DISTRICT BOUNDARIES:** District boundaries are shown within the lines of streets, streams, and transportation right-of-ways shall be deemed to follow the center lines. The vacation of streets shall not affect the location of such district boundaries. When the Zoning Officer cannot definitely determine the location of a district boundary by such center lines, by the scale or dimensions stated on the Zoning Map, or by the fact that it clearly coincides with a property line, he shall refuse action, and the Zoning Hearing Board, upon appeal, shall interpret the location of the district boundary with reference to the scale of the Zoning Map and the purpose set forth in all relevant provisions of this Ordinance.

**204 PERMITTED USES, CONDITIONAL USES AND SPECIAL EXCEPTIONS:** The Permitted Uses, Conditional Uses and Special Exceptions for each district are shown in the following sections and are considered principal uses unless clearly noted. Conditional Uses may be granted or denied by the City Council after the recommendation of the Planning Commission and in accordance with the provisions of this Ordinance. Special Exceptions may be granted or denied by the Zoning Hearing Board in accordance with the express standards and criteria of this Ordinance. In granting a Conditional Use or Special Exception, the City Council or the Zoning Hearing Board, as the case may be, may attach reasonable conditions and safeguards as it may deem necessary to implement the purpose of this Ordinance and protect the neighborhood.

Uses in each category shall be according to the common meaning of the term or according to definitions set forth in Article 6. Only one (1) principal use per lot in any "R District will be allowed except for planned residential development districts.

The following is an excerpt from the Pennsylvanian Municipalities Planning Code:

**10913.2. Governing Body's Functions: Conditional Uses:**

(a) Where the governing body, in zoning ordinances, has stated conditional used to be granted or denied by the governing body pursuant to express standards and criteria, the governing body shall hold hearings on and decide requests for such conditional uses in accordance with such standards and criteria. In granting a conditional use, in addition to those expressed in the ordinance, as it may deem necessary to implement the purposes of this act in the zoning ordinance.

(b)(1) The governing body shall render a written decision or, when no decision is called from, make written findings on the conditional use application within 45 days after the last hearings before the governing body. Where the application is contested or denied, each decision shall be accompanied by findings of fact or conclusions based thereon, together with any reasons therefor. Conclusions based upon any provisions of this act or of any ordinance, rule or regulation shall contain a reference to the provision relied on and the reasons why the conclusion is deemed appropriate in light of the facts found.

(2) Where the governing body fails to render the decision within the period required by this subsection or fails to hold the required hearing within 60 days from the date of the applicant's request for a hearing, the decision shall be deemed to have been rendered in favor of the applicant unless the applicant has agreed in writing or on the record to an extension of time. When a decision has been rendered in favor of the applicant because of the failure of the governing body to meet or render a decision as hereinabove provided, the governing body shall give public notice of the decision writing 10 days of the last day it could have met to render a decision in the same manner as required by public notice requirements of this act. If the governing body shall fail to provide such notice, the applicant may do so.

## **204.10 R-1 LOW DENSITY RESIDENTIAL DISTRICT**

### PERMITTED USES

Accessory Uses and Structures  
Cemeteries (305.15)  
Churches, Places of Worship (305.20)  
Essential Services  
Family Day Care Homes  
Home-Child Care  
Home Occupations  
One-Family Dwellings  
Parks and Playgrounds, Public (205.12)

### SPECIAL EXCEPTIONS

Communication Towers/Antennas  
(305.45.5)  
Group Homes (305.01)  
Neighborhood Center (305.34)  
Planned Residential Development (308)  
Schools (305.20)  
Small Wind Energy Systems (305.53)

**204.11 R-1A TRADITIONAL SINGLE FAMILY DEVELOPMENT**

PERMITTED USES

Accessory Uses and Structures  
Cemeteries (305.15)  
Churches, Places of Worship (305.20)  
Community Garage  
Essential Services  
Family Day Care Homes  
Home-Child Care  
Home Occupations  
One-Family Dwellings  
Parks and Playgrounds, Public (205.12)

SPECIAL EXCEPTIONS

Communication Towers/Antennas  
(305.45.5)  
Group Homes (305.01)  
Neighborhood Center (305.34)  
Planned Residential Development (308)  
Schools (305.20)  
Small Wind Energy Systems (305.53)

## **204.12 R-2 MEDIUM DENSITY RESIDENTIAL DISTRICT**

### PERMITTED USES

One-Family Dwellings  
Two-Family Dwellings  
3- and 4-Family Dwellings (305.25)  
Accessory Uses and Structures  
Bed and Breakfast (305.22)  
Cemeteries (305.15)  
Churches, Places of Worship (305.20)  
Community Garage  
Essential Services  
Family Day Care Home  
Fire Stations (305.17)  
Home Child Care  
Home Occupations  
Neighborhood Center (305.34)  
Off Street Parking Lots (305.10, 305.11)  
Parks and Playgrounds, Public (205.12)  
Townhouses (305.21)  
Utility Substations (305.19)

### SPECIAL EXCEPTIONS

Communication Towers/Antennas  
(305.45.5)  
Group Homes (305.01)  
Planned Residential Development (308)  
Schools (305.20)  
Small Wind Energy Systems (305.53)

## 204.13 R-3 HIGH DENSITY RESIDENTIAL DISTRICT

### PERMITTED USES

One-Family Dwellings  
Two-Family Dwellings  
Multiple-Family Dwellings  
Accessory Uses and Structures  
Adult Day Care  
Bed and Breakfast (305.22)  
Churches-Places of Worship (305.20)  
Community Garage  
Essential Services  
Family Day Care Homes  
Fee-Simple Townhouses  
Fire Stations (305.17)  
Funeral Homes (305.36)  
Group Homes (305.01)  
Home Child Care  
Home Occupation  
Municipal Buildings (305.17)  
Off-Street Parking Lots (305.10, 305.11)  
Parks and Playgrounds, Public (205.12)  
Personal Care Boarding Homes for Adults  
(305.28)  
Schools and Colleges  
Utility Substations (305.19)

### SPECIAL EXCEPTIONS

Commercial/Industrial Wind Energy Systems  
(305.53)  
Communication Towers/Antennas (305.45.5)  
Conversion Apartments (305.27)  
Day Care Centers (305.23)  
Dormitories (305.16)  
Fraternity/Sorority (305.16)  
Hospitals (305.20)  
Nursing/Convalescent Homes (305.33)  
Planned Residential Developments (308)  
Retirement Community (305.30)  
Rooming/Boarding House (305.18)  
Schools (305.20)  
Small Wind Energy Systems (305.53)

## 204.13 RLB RESIDENTIAL LIMITED BUSINESS USE DISTRICT

### PERMITTED USES

One-Family Dwellings  
Two-Family Dwellings  
Multi-Family Dwellings  
Banks and Financial Institutions  
Accessory Uses and Structures  
Adult Day Care  
Bed and Breakfast (305.22)  
Business Offices  
Car Washes  
Churches-Places of Worship (305.20)  
Cleaners  
Computer Users Center  
Community Garage  
Convenience Stores (305.43)  
Corporate Office (305.31)  
Day Care Centers (305.23)  
Essential Services  
Fee-Simple Townhouses  
Florist  
Fitness Center/Gym  
Funeral Homes  
Group Care Facility  
Greenhouses/Nurseries (305.35)  
Home Child Care  
Home Occupations  
Hospitals  
Ice Cream Shop  
Libraries and Museums (305.29)  
Licensed Massage Therapy (305.51) 8/09  
Medical and Dental Clinics (305.32)  
Mobile Homes Park  
Personal Care Boarding Homes for Adults  
(305.28)  
Personal Services  
Public/Semi-Public Uses  
Professional Services  
Off-Street Parking Lots (305.10, 305.11)  
Rooming/Board Homes  
Utility Substations (305.19)  
Video Rental

### SPECIAL EXCEPTIONS

Commercial/Industrial Wind Energy Systems  
(305.53)  
Communication Towers/Antennas  
(305.45.5)  
Dormitories (305.16)  
Fraternity/Sorority (305.16)  
Nursing/Convalescent Homes (305.33)  
Small Wind Energy Systems (305.53)

### CONDITIONAL USES

Limited Correctional Facility (305.50)  
General Correctional Facility (305.50)  
Custodial Care Facility (305.50)

**Note:** Any combination of the permitted uses may be placed on one lot of record

## 204.14 C-1 LOCAL BUSINESS DISTRICT

### PERMITTED USES

Accessory Uses and Structures  
Adult Day Care  
Appliance Sales & Services (305.44)  
Automobile/Camper/RV Sales  
Banks and Business Offices  
Beverage Distributors  
Car Washes  
Cleaners  
Computer Users Center  
Convenience Stores (305.43)  
Corporate Offices (305.31)  
Copy Shops  
Day Care Centers (305.23)  
Drive-In Business (305.10, 305.12, 305.13)  
Eating and Drinking Places  
Essential Services  
Florist  
Fitness Center/Gym  
Funeral Homes  
Gasoline Service Stations (305.10, 305.12)  
Home Child Care  
Home Occupation  
Ice Cream Shop  
Libraries and Museums (305.29)  
Licensed Massage Therapy (305.51) 8/09  
Limited Retail Business (305.44)  
Multiple-Family Dwellings  
Off-Street Parking Lots (305.10, 305.11)  
Personal Services  
Pet Grooming  
Private Clubs  
Professional Services  
Public/Semi-Public Uses (205.12)  
Theaters  
Video Rental

### SPECIAL EXCEPTIONS

Commercial/Industrial Wind Energy Systems  
(305.53)  
Communication Towers/Antennas  
(305.45.5)  
Small Wind Energy Systems (305.53)



## 204.16 C-2 GENERAL BUSINESS DISTRICT

### PERMITTED USES

Accessory Uses and Structures  
Animal Care/Pet Grooming (305.37)  
Appliance Sales and Service  
Automobile/Camper/RV Sales  
Automotive Body/Repair Shop  
Banks and Business Offices  
Beverage Distributors  
Business Services  
Car Washes  
Cleaners  
Commercial Recreation  
Computer Users Center  
Convenience Stores (305.43)  
Copy Shops  
Corporate Offices  
Day Care Centers (305.23)  
Drive-In Businesses (305.10, 305.12,  
305.13)  
Eating and Drinking Places  
Essential Services  
Fitness Center/Gym  
Flea/Farmers Market  
Florist  
Funeral Homes  
Gasoline Service Stations (305.10, 305.12)  
Home Child Care  
Hotels and Motels  
Home Occupation  
Ice Cream Shop  
Licensed Massage Therapy (305.51) 8/09  
Massage Parlors (305.41)  
Mobile Home and Trailer Sales (305.39)  
Multiple-Family Dwellings  
Off-Street Parking Lots (305.10, 305.11)  
Parking Garages/Ramps  
Personal Self Storage Facilities  
Personal Services  
Private Clubs  
Professional Services

Public/Semi-Public Uses (205.12)  
Radio and Television Broadcasting  
Research Laboratories (305.31)  
Retail Business  
Service Garage (305.10, 305.12)  
Signs/Outdoor Advertising  
Stations and Studios  
Tattoo Parlors  
Theaters  
Used Car Sales Lot  
Video Rental

### SPECIAL EXCEPTIONS

Commercial/Industrial Wind Energy Systems  
(305.53)  
Communication Tower/Antennas (305.45.5)  
Business Uses Similar to Permitted Uses  
in this District Not Otherwise Specified  
(305.40)  
Small Wind Energy Systems (305.53)

### CONDITIONAL USES

Adult Book Store (305.41)  
Adult Live Entertainment (305.41)  
Adult Mini-Motion Picture Theater (305.41)  
Adult Motion Picture Theater (305.41)

## 204.17 C-3 CENTRAL BUSINESS DISTRICT

### PERMITTED USES

Accessory Uses and Structures  
Banks and Business Offices  
Business Services  
Cleaners  
Commercial Recreation  
Communication Antennas (305.45)  
Convenience Stores  
Copy Shops  
Corporate Offices  
Day Care Centers (305.23)  
Eating & Drinking Places  
Essential Services  
Fitness Center/Gym  
Florist  
Hotels and Motels  
Home Child Care  
Ice Cream Shop  
Libraries and Museums  
Licensed Massage Therapy (305.51) 8/09  
Light Manufacturing (305.38)  
Multiple-Family Dwellings  
Parking Garages/Ramps  
Personal Services  
Printing and Engraving  
Private Clubs  
Professional Services  
Public/Semi-Public Uses (205.12)  
Radio and Television Broadcasting  
Stations and Studios  
Retail Business  
Signs/Outdoor Advertising  
Theaters

### SPECIAL EXCEPTIONS

Bottle Clubs (305.42)  
Commercial/Industrial Wind Energy Systems  
(305.53)  
Communication Towers/Antennas (305.45)  
Drive-In Business (305.10, 305.12)  
Gasoline Service Stations (305.10, 305.12)  
Business Uses Similar to Permitted Uses in  
this District not Otherwise Specified  
(305.40)  
Small Wind Energy Systems (305.53)

## 204.18 C-4 TRADITIONAL NEIGHBORHOOD COMMERCIAL

### PERMITTED USES

Accessory Uses and Structures  
Banks and Financial Institutions  
Bed and Breakfast  
Churches, Places of Worship  
Cleaners  
Computer Users Center  
Convenience Stores (305.43)  
Day Care Center (305.23)  
Dental and Medical Clinics (305.32)  
Eating/Drinking Establishments  
Family Day Care Home  
Fitness Center/Gym  
Florist  
Funeral Homes  
Home Child Care  
Home Occupation  
Ice Cream Shop  
Libraries and Museums (305.29)  
Licensed Massage Therapy (305.51) 8/09  
Limited Retail Business (305.44)  
Multiple Family Dwellings  
Personal/Professional Services  
Single Family Dwellings when located  
with any other permitted use  
Theaters  
Video Rental

### SPECIAL EXCEPTIONS

Cellular Towers/Antennas  
(305.45.5)  
Commercial/Industrial Wind Energy  
Systems (305.53)  
Small Wind Energy Systems (305.53)

## 204.19 M-1 LIGHT MANUFACTURING DISTRICT

### PERMITTED USES

Accessory Uses  
Automotive Body Shop  
Automotive Paint Shop  
Automotive Repair Shop  
Chemical Processing and Production  
Contractors Yard  
Corporate Offices  
Essential Services  
Light Manufacturing  
Off-Street Parking Lots (305.10, 305.11)  
Personal Self Storage Facilities  
Radio and Television Broadcasting Stations  
And Studios  
Rental Service and Equipment  
Service Garage  
Signs/Outdoor Advertising  
Supply Yards  
Truck Terminals  
Urban Solar Farms (305.55)  
Warehousing  
Wholesale Distribution Center

### SPECIAL EXCEPTIONS

Commercial/Industrial Wind Energy Systems  
(305.53)  
Communication Towers/Antennas (305.45)  
Small Wind Systems (305.53)

### CONDITIONAL USE

Wind Energy Conversion Systems (305.52)

## 204.20 M-2 HEAVY MANUFACTURING DISTRICT

### PERMITTED USES

Accessory Uses  
Airports and Heliports  
Asphalt Products, Manufacturing and Storage  
Automotive Body Shop  
Automotive Paint Shop  
Automotive Repair Shop  
Chemical Processing and Production  
Commerical Recreation (8/07)  
Contractors Yard  
Corporate Offices  
Essential Services  
Gasoline Service Station (305.10, 305.12)  
Heavy Manufacturing (305.47)  
Landfill/Solid Waste Transfer Facility  
Light Manufacturing  
Off-Street Parking Lots (305.10, 305.11)  
Power Plants  
Personal Self Storage Facilities  
Recycling and Refuse Reduction Center  
Service Garage  
Signs/Outdoor Advertising  
Supply Yards  
Truck Terminals  
Urban Solar Farms (305.55)  
Warehousing

Commercial/Industrial Wind Energy Systems (305.53)  
Communication Towers/Antennas (305.45)  
Any other Manufacturing use not otherwise specified which is not objectionable to immediate neighbors because of noise, vibration, or emission of noxious gases, fumes or dust (305.49)  
Small Wind Energy Systems (305.53)

### CONDITIONAL USES

Scrap Yards (305.48)  
Wind Energy Conversion Systems (305.52)

**PLEASE SEE SECTION 206 FOR THE INDUSTRIAL PARK DISTRICT, I.P.**

### SPECIAL EXCEPTIONS

## 204.21 W-C WATERFRONT COMMERCIAL DISTRICT

### CONDITIONAL USES

Accessory Uses  
Aquariums  
Business and Professional Offices  
Banks  
Boat Sales and Rentals  
Commercial/Industrial Wind Energy  
Systems (305.53)  
Commercial Recreation  
Communication Towers/Antennas  
(305.45.5)  
Convention Center  
Eating and Drinking Places  
Essential Services  
Home Child Care  
Hotels, Motels and Inns  
Libraries and Museums  
Marinas  
Marine Gas Stations  
Mass Transit Center  
Multiple-Family Dwellings  
Museums  
Off-Street Parking Lots  
Parking Garages/Ramps  
Personal Service  
Private Clubs  
Parks and Playgrounds (205.12)  
Public/Semi-Public Uses  
Retail Business  
RV Parks  
Small Wind Energy Systems (305.53)  
Theaters  
Wagering & Betting Uses

## **204.21.1 W-C2 WATERFRONT COMMERCIAL DISTRICTS**

### **CONDITIONAL USES**

Accessory Uses  
Aquariums  
Business and Professional Offices  
Banks  
Boat Sales and Rentals  
Commercial/Industrial Wind  
    Energy Systems (305.53)  
Commercial Recreation  
Communication Towers/Antennas (305.45.5)  
Convention Center  
Custodial Care Facility (305.50)  
Eating and Drinking Places  
Essential Services  
Home Child Care  
Hotels, Motels and Inns  
Group Care Facilities  
Libraries and Museums  
Marinas  
Marine Gas Stations  
Mass Transit Center  
Multiple-Family Dwellings  
Museums  
Off-Street Parking Lots  
Parking Garages/Ramps  
Personal Service  
Private Clubs  
Parks and Playgrounds (205.12)  
Public/Semi-Public Uses  
Retail Business  
RV Parks  
Small Wind Energy Systems (305.53)  
Theaters  
Wagering & Betting Uses

## **204.21.2 W-C3 WATERFRONT COMMERCIAL HAMMERMILL DISTRICT**

### **CONDITIONAL USES**

Accessory Uses  
Animal Care  
Aquariums  
Banks  
Commercial/Industrial Wind  
    Energy Systems (305.53)  
Commercial Recreation/Racetrack  
Communication Towers/Antennas (305.45.5)  
Convention Center  
Eating and Drinking Places  
Essential Services  
Hotels, Motels and Inns  
Home Child Care  
Limited Retail (a)  
Libraries and Museums  
Light Manufacturing  
Marinas/Marine Gas Station  
Multiple Family Dwellings  
Offices  
Off Street Parking (305.11)  
Parks and Playgrounds (205.12)  
Parking Garages  
Personal Services  
Private Clubs  
Public/Semi Public Uses  
Small Wind Energy Systems (305.53)  
Theaters  
Warehousing  
Waging and Gaming

(a) Limited Retail shall be defined for this district only as follows: Limited Retail is permitted for the sale of products which enhance the overall development complex. Each individual retail location shall not exceed three thousand (3,000) square feet in total floor area and any one structure used primarily for the purpose of retail shall not exceed seven thousand (7,000) square feet total floor area.



## **204.22 W-M WATERFRONT INDUSTRIAL DISTRICT**

### CONDITIONAL USES

Accessory Uses  
Chemical Processing and Production  
Corporate Offices  
Commercial/Industrial Wind  
    Energy Systems (305.53)  
Communication Towers/Antennas (305.45.5)  
Essential Services  
Heliport  
Light and Heavy Manufacturing  
Off-Street Parking Lots (305.10, 305.11)  
Power Plants  
Small Wind Energy Systems (305.53)  
Truck Terminals  
Urban Solar Farms (305.55)  
Warehousing  
Wind Energy Conversion Systems (305.52)

## **204.22 W-R WATERFRONT RESIDENTIAL DISTRICT**

### CONDITIONAL USES

One-Family Dwellings  
Two-Family Dwellings  
Multiple Family Dwellings  
Accessory Uses  
Churches-Places of Worship  
Commercial/Industrial Wind  
    Energy Systems (305.53)  
Communication Towers/Antennas  
    (305.45.5)  
Essential Services  
Family Day Care Homes  
Home Occupations  
Home Child Care  
Off-Street Parking Lots (305.10, 305.11)  
Parks and Playground – Public (205.12)  
Small Wind Energy Systems (305.53)

**\*NOTE ALL USES IN W-C, W-M AND W-R DISTRICTS ARE CONDITIONAL USES AND  
SUBJECT TO PROVISIONS OF SECTION 306 HEREIN**

**205 LOT, YARD AND HEIGHT REQUIREMENTS:** The minimum lot area per family, maximum lot coverage by buildings and structures, minimum depth of front yard, minimum depth of rear yard, total combined width and minimum width of side yards, maximum height of structures and number of stories, and minimum floor area per dwelling for each district shall be specified in the following tables:

USE DISTRICTS	R-1	R-1A	R-2	R-3	RLB
Minimum Lot Area Per Family (Square Feet)	6,000 (A)	6,000 (A)	3,000 (A,L)	1,000 (2-1975)	1,500
Maximum Lot Coverage by Buildings	35%(I)	50%(I)	50%(I)	50%(I)	50%(I)
Minimum Depth of Front Yard (Feet)	30(BG)	(BG)	(BG)	(BG)	(BG)
Minimum Depth of Rear Yard (Feet)	30(DJ)	20(DJ)	20(DJ)	15(DJ)	30(DJ)
Minimum Total Width of Side Yards (Feet)	15(J)	6 (J)	6 (J)	6 (HJ)	15(J)
Minimum Width of Least Side Yards (Feet)	5(J)	3 (J)	3 (J)	3 (H)	5(J)
Maximum Height of Structure (Feet)	35	35	35	100(F)	35 (K)

- (A) Use of lot of record 205.10
- (B) Front yard adjacent setback 205.11
- (C)
- (D) Rear yard with alley or irregular shape 205.13
- (E) Side and rear yards adjacent to any "R" District 205.14
- (F) Height exceptions, chimney, towers, spires 205.15
- (G) Minimum front yard for garage whenever the garage doors face the street 205.23
- (H) Increased side yard above second story 205.24
- (I) Exclusive of roofless decks pools, roofless walkways 205.25
- (J) Side and rear yard of existing nonconforming principal buildings 205.26
- (K) Height exception in RLB District for Hospitals 205.32
- (L) 3 & 4 family dwellings in "R-2" 305.24

**205 LOT, YARD AND HEIGHT REQUIREMENTS**

USE DISTRICTS	C-1	C-2	C-3	C-4	M-1
Minimum Lot Area Per Family (Sq Ft)	1,500	1,000	1,000 (C)	1,000	N/A
Maximum Lot Coverage By Buildings	35%(I)	50% (I)	100%	100%	70%(I)
Minimum Depth of Front Yard (Feet)	15(G) (M)	(GM)	(K)	(KN)	30
Minimum Depth of Rear Yard (Feet)	(E J) (M)	(E J) (M)	(E J)	(EJ)	30
Minimum Total Width of Side Yards (Feet)	N/A (M)	N/A (M)	N/A	N/A	20
Minimum Width of Least Side Yards (Feet)	(EJ) (M)	(EJ) (M)	(EJ)	(EJ)	10 (EJ)
Maximum Height of Structure (Feet)	45 (M)	45(F) (M)	(L)	45 (M)	100(F)

\*N/A - NOT APPLICABLE

- (A) Use of lot of record 205.10
- (B) Front yard adjacent to existing building 205.11
- (C) Lot area per family shall equal one dwelling unit for every 1,000 Sq Ft of Building Size (2/28/07)
- (D) Rear yard with alley or irregular shape 205.13
- (E) Side and rear yards adjacent to any "R" District 205.14
- (F) Height exceptions, chimney, towers, spires 205.15
- (G) Minimum front yard for garage whenever the garage doors face the street 205.23
- (H) Increased side yard above second story 205.24
- (I) Exclusive of roofless decks, in-ground pools, roofless walkways 205.25
- (J) Side and rear yard of existing nonconforming principal buildings 205.26
- (K) No front yard setback permitted 205.29
- (L) As controlled by Airport Zoning Ordinance --
- (M) Multi-family use will use R-3 yard and lot requirements --
- (N) Front Yard Setback for residential structures 205.30

## 205 LOT, YARD AND HEIGHT REQUIREMENTS

USE DISTRICTS	M-2	W-C	WC-2	WC-3	W-M	W-R	I-P
Minimum Lot Area Per Family (Sq Ft)	N/A	1,000 (M)	1,000	1,000	N/A	1,000	N/A
Max Lot Coverage By Buildings	100%	65%	65%	100%	100%	50%(I)	60% (K)
Minimum Depth of Front Yard (Feet)	(CG)	(GM)	(G)	0 or 30 abuts R district	(G)	(BGM)	25(K)
Minimum Depth of Rear Yard (Feet)	(E J)	(E J) (M)	(E J)	0 or 30 abuts R district	(E J)	20 (DJ) (M)	10 (K J)
Min. Total Width of Side Yards (Feet)	N/A	N/A (M)	N/A	0 or 30 abuts R district	N/A	<sup>6</sup> (HM)	20(K)
Min. Width of Least Side Yards (Feet)	(EJ)	(EJ) (M)	(EJ)	0 or 30 abuts R district	(EJ)	<sup>3</sup> (HJM)	10(K)
Maximum Height of Structure (Feet)	100 (F)	50(F) (M)	100	100(F)	100 (F)	50(F) (M)	50(K)

\*N/A - NOT APPLICABLE

(A) Use of lot of record	205.10
(B) Front yard adjacent to existing building	205.11
(C)	
(D) Rear yard with alley or irregular shape	205.13
(E) Side and rear yards adjacent to any "R" District	205.14
(F) Height exceptions; chimney, towers, spires	205.15
(G) Minimum front yard for garage whenever the garage doors face the street	205.23
(H) Increased side yard above second story	205.24
(I) Exclusive of roofless decks, in-ground pools, roofless walkways	205.25
(J) Side and rear yard of existing nonconforming principal buildings	205.26
(K) Manufacturing park requirements	205.29
(L) As controlled by Airport Zoning Ordinance	--
(M) Multiple-family use will use R-3 yard and lot requirements	--

**205.10** Any lot of record existing at the effective date of this amendment and held in separate ownership different from ownership of adjoining lots may be used and occupied by a single family dwelling even though its lot area per family is less than the minimum requirement of this Ordinance.

Any lot of record in the R-1 district existing before the effective date of this Ordinance and having a lot width of less than forty-one (41) feet, in width may reduce the side yard requirements to a total of ten (10) feet, with a minimum side yard of at least three (3) feet.

**205.11** In any appropriate district where a structure exists on the applicant's lot or any adjacent lot the required depth of front yard for the proposed structure shall be the average depth of the existing structures located between two intersecting streets within a tolerance of +/- five (5) feet.

**205.12** Accessory structures customarily associated with parks and playgrounds shall be allowed on site without a principal structure. Such structures may include, but are not limited to picnic pavilions, gazebos, and equipment storage sheds.

**205.13** In measuring the depth of side and rear yards, where the lot line is not parallel with the front the average dimension may be used, and where the lot line abuts an alley one-half the width of the alley may be considered as a portion of the required yard space.

**205.14** The side yard and rear yard of any "C," "W-C," "M" or "W-M" District adjoining any "RLB" or any "R" or "W-R" District shall be at least one (1) foot for each one (1) foot of building height and shall have a screen planting strip adjoining the "R" District which shall be protected from automobiles by wheel barriers or guard rails. However, in no event shall side yards be less than that set forth by the tables in Section 205.

**205.15** Appurtenances to buildings, chimneys, stacks, elevator bulkheads, penthouses, gas or water towers, cooling towers, stage towers or scenery lofts, electric signs, wireless towers, and other necessary mechanical appurtenances, where permitted by Building Code and Use Regulations, and erected upon and as an integral part of the building, or a monument, shaft, spire, dome, tower, if erected for ornamental purposes only, may be erected or extended above the height limit of the district, provided that any such structure shall set back from the vertical plane of the permitted building line one (1) foot horizontally for each two (2) feet of extra height.

**205.16** Corner lots shall be considered to have 2 front yards and two (2) side yards. In "R" and "W-R" Districts the minimum depth of front yards facing one street only may be reduced to the extent necessary to permit the construction of a dwelling up to twenty two (22) feet in width or depth.

**205.17** All structures attached to the principal structure, excluding detached accessory structures, and whether open or enclosed, including porches, carports, attached garages,

balconies, and bay windows above grade level, shall comply with all the required front, side and rear yards. Handicap ramps without a roof or enclosed sides are exempt from this rule.

**205.18** In any “R” District detached accessory buildings shall be located in the side or rear yard of the principal building, at least six (6) feet from any dwelling or alley, at least three (3) feet from any side and/or rear property line. Detached accessory buildings shall be no larger than seven hundred and twenty (720) square feet in size or 15 feet in height. (See illustration No 1 – p. 140) Accessory structures located less than six (6) feet from the principal structure shall be considered attached and must conform to the setback requirements of Section 205. No requirement for maximum building coverage or setbacks contained in this ordinance shall prevent the construction of a shed which does not exceed 100 square feet in size.

In all other zoning districts, detached accessory buildings shall meet the setback, height and lot coverage requirements for that district and shall be located in the side or rear yard setback area.

Swimming Pools shall be located in the side or rear yard of the principal building. Detached pools, with or without a deck, shall be considered as being a minimum of six (6) feet from any dwelling. The rear and side yard setback detached pool is six (6) feet. Swimming pools attached to the home must meet all the requirements set forth in Section 205, Lot, Yard and Height Requirements.

**205.19** In a Residential District any fence, hedge or enclosure within the required yard space shall not exceed a height of six (6) feet six (6) inches. In a non-Residential District any fence, hedge or enclosure within the required yard space shall not exceed a height of eight (8) feet six (6) inches. Where there is a boundary line between the two districts, the less restrictive 8’6” height shall be permitted.

The height of any fence, hedge or enclosure shall be measured from the maximum grade level on either side of the property to the top of the fence, hedge or enclosure. Where a fence and a wall are combined, the top of the fence/wall shall be restricted by the maximum height as noted above.

Any fence, hedge or enclosure that is not of a "see-through" nature and obstructs vision, and is located within fifteen (15) feet of a driveway or alley where the driveway or alley intersects a front property line, or is located within fifteen (15) feet from a point where two front property lines intersect, shall not exceed a height of (30) inches above the top of the curb. Seventy percent (70%) of the fence, hedge or enclosure's area shall be open to be considered "see-through."

Chain Link fences to protect utility substations, pump houses, reservoirs may be increased in height to allow additional safety and security.

All dumpsters in the “C”, “R”, or “W” districts must be screened from view on a minimum of three (3) sides.

**205.20** A roof eave or overhang of a roof shall not project more than twelve (12) inches into required yard spaces. For larger overhangs, the building shall be set back accordingly.

**205.21** Not more than one (1) house trailer, travel trailer, recreational vehicle, camper trailer, utility trailer, boat trailer, or boat may be stored in any "R" District, provided that it shall be stored at least three (3) feet from the property line and behind the principal structure. At no time shall any item listed above be used as living quarters except in properly zoned RV/Mobile Home parks.

**205.22** Not more than one truck (pick-up, panel delivery, flat bed or panel delivery) used for commercial purposes, may be stored or parked on a lot in any "R" and "W-R" District, provided it is required for the occupant to travel to and from work. Vehicles not permitted under this section include but are not limited to the following: dump trucks, bucket trucks, buses, tow trucks, tractor trailers, garbage and/or scrap hauling trucks or any other equipment or vehicles normally associated with the construction industry. Non-conforming commercial uses within the "R" district are exempt from this regulation.

**205.23** Minimum distance between any street property line and any garage doors facing same shall be twenty (20) feet with a clear, unobstructed clear sight area extending five (5) feet on either side of the driveway at the street property line and five (5) feet deep.

**205.24** In R-3 and "W-R" Districts each side yard shall be increased by three (3) feet per story above the second story.

**205.25** Maximum lot coverage by buildings as indicated in Section 205 shall not include ground floor roofless decks, swimming pools, and roofless walkways, but shall be required to meet setback requirements.

**205.26** Existing nonconforming principal buildings, whose use is conforming to the zone in which it is located, may be expanded where the addition infringes into setback areas, only to the extent that the existing principal structure currently infringes into such areas exclusive of bay windows, chimneys, etc. This only applies to additions of two (2) stories or under.

**205.27** Rear additions to principal buildings may protrude behind the front line of an existing detached accessory structure provided that the side and rear yard setbacks for the addition are met and a minimum of six (6) feet is maintained between the addition and the detached accessory structure.

**205.28** Existing open porches may be enclosed where the enclosure will project into the required front yard and/or side yard space, provided that the structure was built prior to the enactment of this Ordinance, there are other open porches extending into the front yard an equal distance within the same block frontage. "In addition, front porches/balconies may be replaced



if the porch/balcony infringes into side and front yard setback areas, provided that the new porch size and location is within the existing porch's area."

**205.29** In C-3 Districts, no building may be set back in any degree from the front property line, exclusive of the public right-of-way. The Central Commercial District shall promote and maintain the high-density urbanized commercial patterns that are fundamental to downtown areas and to insure a feeling of large-scale development with properties utilized to their fullest." Any existing structure in this district shall be permitted an addition or alteration to the front of the structure even if that addition does not extend to the right of way. This exception does not include side additions which continue the existing front yard setback.

**205.30** In the C-4 zoning district, structures which are proposed for residential use only shall be allowed a variable setback of zero to fifteen (0-15) foot setback.

**205.31** Hospitals located in "RLB" Districts shall meet height requirements set forth in "R-3" Zoning Districts.

## **206 INDUSTRIAL PARK (I. P.) DISTRICT REGULATIONS**

### **A. PURPOSE - INDUSTRIAL PARK**

The Industrial Park (IP) Districts are created as an area to be developed exclusively for industrial activity but with more restrictions than an Industrial designation. These districts encourage the use of industrial park development. Such development treats a large expanse of land as an industrial subdivision by planning, construction, servicing and maintaining it in a manner that will make resourceful use of the land, increase the compatibility and attractiveness of these uses to each other, and protect the City's advantage in attracting industry. All requirements in this Ordinance shall govern for the Industrial Park designation except where specific exceptions or additions are provided.

The intent and purposes of the City of Erie in creating this district is as follows:

To encourage the establishment of industries which are compatible with one another.

To establish standards for the height and size of buildings, the areas and dimensions of yards and open spaces.

To provide development and operational standards for yards, structures and equipment that will minimize traffic congestion, noise, glare, air pollution, fire and safety hazards and insure adequate drainage.

To provide standards for off-street automobile parking and storage and loading facilities adequate in area, design, arrangement and development to properly serve the users for which such facilities are intended and sufficient to preclude the need for on-street parking or storage of automobiles and trucks.

To provide standards for the location and illumination of signs and advertising devices so as to minimize glare and distraction to motorists and neighboring residential districts.

To prohibit commercial uses except as such uses are purely accessory and incidental to the industrial uses they are intended to serve.

To prohibit industrial uses which, because of potential emission of dust, ash, smoke, noise, fumes, gas, odors or vibrations, are or may be inconsistent with the intent and purposes of this section.

To establish standards for environmental development including landscaping and requirement of open areas that will tend to result in healthful and productive working conditions.

To prohibit residences or any structures intended for living purposes.

## **B. PERMITTED USES - INDUSTRIAL PARK**

Only those industrial, industrial, compounding, processing, packaging or treatment uses and processes from the following listing are permitted when and if they do not represent a health or safety hazard to the community through air, water, and noise pollution including the production or emission of dust, smoke, refuse matter, toxic or noxious odors, explosives, gas and fumes, excessive noise or similar substances and conditions.

No use shall be permitted in a Light Industrial Park district which shall have noise levels sustained or periodic of sixty (60) (dbA) or greater or unsustained non-periodic noise levels of eighty (80) decibels (dbA) or greater as measured at any property line and residential district line.

Principal Use:

1. Wholesale warehousing and storage.
2. Highway freight, transportation and warehousing.
3. Transportation terminals.
4. Distributing plants, beverages, bottling and/or distribution.
5. The industrial, compounding, processing/packaging, treatment and distribution of such products as bakery goods, candy, cosmetics, pharmaceuticals, toiletries, food and kindred products.
6. Laboratories devoted to research, design, experimentation, processing and fabrication incidental thereto.
7. Utility operations (electric and gas company operations, sewer and water authorities).
8. Radio and television facilities and operations, telephone exchange and transformer stations.
9. Carpenter, electrical, plumbing, welding, heating or sheet metal shop, furniture upholstery shop, laundry and clothes cleaning establishments, printing shop or publishing plant.
10. Building material supplies, but not including stone crushing or concrete mixing.
11. Assembly, industrial, compounding, processing, packaging or treatment uses or processes which produce or emit dust, smoke or toxic or noxious odors, gases, fumes and noise levels which are in conformance with Environmental Protection Agency and Pennsylvania Department of Environmental Resources standards.
12. Office buildings and buildings used for research and development (R&D) facilities.
13. Temporary outdoor storage of commodities for transshipment.

14. Essential services and utility substations.
15. Training facilities or schools which complement any Permitted Use.
16. Printing and Publishing facilities.
17. Plastics manufacturing.
18. Agri-business.
19. Urban Solar Farms (305.55)

### **C. ACCESSORY USES - INDUSTRIAL PARK**

The following special uses shall be permitted in an Industrial Park District providing the buildings and accessory buildings and uses comply with off-street parking requirements.

1. Cafeterias or restaurants specifically designed and intended for use by those employees and management of permitted uses in the Industrial Park District.
2. Indoor recreational facilities, auditoriums, meeting rooms, or other buildings primarily intended for the mutual use of the permitted uses located within the district, for meetings, programs, displays, recreation and other such uses as the users of the district may deem necessary. These facilities shall be prohibited for use by organizations, clubs and fraternities not specifically a part of the users of the district.
3. Outdoor recreational facilities designed and intended for use by employees and management of those permitted uses within the district. These facilities and associated uses shall comply with all requirements of this Section in respect to front yard, side yard, and rear yard clearances. These facilities, if lighted, must be shielded away from any thoroughfares and Residential districts.
4. All heliports shall be licensed by the Pennsylvania Department of Transportation, Bureau of Aviation, and shall meet minimum requirements specified by the Federal Aviation Administration or other governing agency.

### **C-A . CONDITIONAL USES - INDUSTRIAL PARK**

Wind Energy Conversion Systems (305.52)

## **C-B . SPECIAL EXCEPTIONS - INDUSTRIAL PARK**

Commercial / Industrial Wind Energy Systems (305.53)  
Small Wind Energy Systems (305.53)

## **D. PROHIBITED USES - INDUSTRIAL PARK**

1. All those uses not specifically stated as permitted uses in an Industrial Park District are prohibited.

## **E. MINIMUM LOT AREA AND LOT WIDTH - INDUSTRIAL PARK**

1. All buildings or structures permitted in the Industrial Park District shall be located on a lot having a minimum area of forty thousand (40,000) square feet and a minimum frontage on a public thoroughfare of one hundred (100) feet. Lots fronting a cul-de-sac shall provide the one hundred (100) feet frontage at the required building line land areas dedicated to essential services and utility substations shall be excluded from this requirement.

## **F. YARDS REQUIRED - INDUSTRIAL PARK**

1. Front Yards: There shall be a front yard of not less than twenty-five (25) feet, measured from the street right-of-way. Such yards shall be appropriately landscaped and maintained as per M.4. of this Ordinance.
2. Side Yards: Each side yard shall have a width of not less than ten (10) feet. Such yards shall be appropriately landscaped and maintained as per M.4. of this Ordinance. For lots abutting any Residential District, as defined in this Zoning Ordinance, there shall be a side yard clearance for the side abutting the Residential District of not less than fifty (50) feet. The fifty (50) feet abutting the Residential District shall be appropriately landscaped and maintained as per M.4. of this Ordinance. Such space shall remain open and unoccupied by any principal or accessory building use.
3. Rear Yards: There shall be a rear yard of not less than fifteen (15) feet. Such yards shall be appropriately landscaped and maintained as per M.4. of this Ordinance. For those lots with rear lot lines abutting any Residential District, there shall be a rear yard of not less than fifty (50) feet. The fifty (50) feet abutting the Residential District shall be appropriately landscaped and maintained as per M.4. of this Ordinance. Such space shall remain open and unoccupied by any principal or accessory building or use.

## **G. BUILDING HEIGHT LIMITS - INDUSTRIAL PARK**

1. Except as provided in sub-section 2. following, no building or structure shall exceed a height of fifty (50) feet.

2. Other Structures: Chimneys, water tanks, storage and fuel tanks, communication towers and antennae, ventilators and other similar structures, whether or not accessory to building or appurtenant thereto may be erected to a height exceeding fifty (50) feet provided they are in compliance with the applicable Federal Regulations relative to objects affecting navigable air space and the City of Erie Airport Zoning Ordinance.

## **H. PERCENTAGE OF LOT COVERAGE - INDUSTRIAL PARK**

Not more than sixty percent (60%) of the lot area shall be covered by any main and accessory building.

## **I. OFF-STREET PARKING - INDUSTRIAL PARK**

Space for off-street parking of employees, customers and visitors shall be required in the following manner and in accordance with other sections of this Zoning Ordinance governing off-street parking. There shall be no on-street parking permitted in an Industrial Park under this zoning classification.

1. Off-street parking space shall herein be interpreted to be an accessory use and shall conform to all requirements as to side yard and rear yard clearances and shall provide one parking space for every five hundred (500) square feet of floor area or as required elsewhere by this Ordinance.
2. All parking spaces provided in the district shall be located on the same property with the permitted use it is intended to serve and conform to the landscaping requirements described in Section M.4. of this Ordinance.
3. Sufficient parking spaces for employees, customers and visitors shall be provided. Visitor-only parking shall be permitted to the front of the building and in all cases there shall be at least twenty five (25) feet from the front line of parking lot to the street right-of-way. Parking to the front of the building shall not exceed ten percent (10%) of all the required spaces except for lots along "main thoroughfares" where this restriction shall not apply. All parking shall conform to Section F. Yard Requirements of this Ordinance.
4. Space shall be provided for the parking of freight and delivery trucks during any time in which the off-street loading facilities prescribed in the Ordinance are insufficient to handle all such trucks waiting to use said facilities.
5. All off-street parking areas shall be graded to drain to a City storm sewer wherever available. Where storm sewers are not available, the owner shall provide other feasible means of draining the lot, subject to the approval of the City Engineer.

## **J. OFF-STREET LOADING/UNLOADING AND STORAGE - INDUSTRIAL PARK**

Space for off-street loading/unloading and storage shall be required in the following manner and in accordance with other sections of the Ordinance governing loading requirements.

1. Off-street loading/unloading and storage space shall herein be interpreted to be an accessory use and shall conform to all requirements as to front, side and rear yard clearances as specified in this Zoning Ordinance.
2. All loading/unloading and storage space shall be located on the same property with the permitted use it is intended to serve.
3. All open areas used for storage of any type shall be enclosed by a solid wall or fence. All such solid walls or fences shall be a minimum of seven (7) and a maximum of fifteen (15) feet in height and in no case shall storage of materials be permitted to exceed the height of the fence. Storage shall be limited to materials in accordance with the standards of the Pennsylvania Department of Environmental Resources, the Environmental Protection Agency and State Fire Marshall regulations.
4. In no case shall storage spaces or loading/unloading facilities be permitted in front of any main building.
5. All loading/unloading facilities shall be located a minimum of one hundred (100) feet from any Residential District boundary if operated between the hours of 6:00 p.m. and 7:00 a.m.
6. Sufficient area shall be provided for loading/unloading and storage of motor vehicles used in the conduct of the commercial or industrial activity.
7. All off-street loading/unloading and storage areas shall be graded to a City storm sewer wherever available. Where storm sewers are not available, the owner shall provide other feasible means of draining the area, subject to the approval of the City Engineer.

## **K. SIGNS AND LIGHTING REQUIREMENTS - INDUSTRIAL PARK**

1. Signs
  - a. Only identification signs identifying the name and commercial of the persons or firms occupying the premises and directional signs necessary for proper automobile and truck delivery traffic shall be permitted. Advertising signs, billboards, or other signs are prohibited. No free-standing sign shall be larger than sixty (60) square feet. No sign mounted flush to the wall shall be larger than one hundred (100) square feet.

Identification signs shall generally be placed upon the outside walls of the buildings, but shall not extend above the line of the roof meeting the wall. However, identification signs may be placed in the front yard setback area when they are constructed and designed to be a part of a landscaping element. All other signs in the front yard setback area, signs painted on exterior faces of buildings or on roofs or fences, flashing or moving signs are prohibited. Signs shall not be placed or externally illuminated in a manner which casts glare or is otherwise detrimental to neighboring occupancies or to the safe movement of traffic.

- b. No sign shall be located within fifty (50) feet of any intersection unless affixed to a building and not extending more than three (3) feet beyond the same.
- c. No sign shall be erected or maintained in any yard which will in any way obstruct a view of any street intersection or otherwise create a traffic hazard.
- d. Sign permits shall be required for any exterior signs.
- e. Industrial Park identification signs shall be exempt from these requirements.

## 2. Glare and Lights Standards

- a. Lighting, including spot lights, flood lights, electrical reflectors and other means of illumination for signs, structures, landscaping, parking areas, loading and unloading areas and the like shall be focused, directed, and so arranged as to prevent glare or direct illumination on streets adjoining property lines, or any residential or agricultural district lines unless required to illuminate a hazard.

## **L. STREETS - INDUSTRIAL PARK**

All streets in any Industrial Park District must be public streets and shall meet the following standards.

- 1. All streets shall have a minimum right-of-way width of sixty (60) feet.
- 2. All streets shall have a paved cartway with a minimum width of thirty (30) feet.
  - a. Street development shall conform with the City of Erie Subdivision Ordinance.
- 3. Sidewalks will only be required along main thoroughfares abutting on or passing through Industrial Park Districts. Sidewalks will only be required on one side of main thoroughfares. All intersections shall have a minimum curb radii's of thirty-five (35) feet.

## **M. SUPPLEMENTAL CONDITIONS - INDUSTRIAL PARK**

- 1. Vibration Standards: Permitted uses shall not be permitted to provide vibration in excess of these standards.



- a. Requirements: Every use shall be so operated that ground vibration inherently and recurrently generated is not perceptible without instruments.
  - b. Method of Measurement: Any vibration recurrently generated that is perceptible to the normal senses, without instruments, is prohibited.
  - c. Locational Requirement: Vibration shall be determined along the property line of the property on which the use is located.
2. Storm Drainage Standards: Storm drainage facilities in streets shall be designed to accommodate a 25-year storm. No storm water pipes smaller than fifteen (15) inches in diameter shall be permitted. All cross pipes used in streets shall be reinforced concrete pipe - Class IV or PVC SDR 35 or equivalent. Parallel pipes may be concrete or coated corrugated galvanized steel pipe, Type B.

For lots greater in size than two-and-one-half (2½) acres, storm water discharge rate after development for storm frequencies of five (5), ten (10) and twenty-five (25) years shall not exceed pre-development discharge rates.

3. Solid Waste and Refuse Standards: The disposal of solid waste and refuse must be in conformance with the requirements of the Pennsylvania Department of Environmental Resources. All refuse containers shall be kept in rear of the principal building and shall be surrounded by fencing on three sides for screening purposes.
4. Landscaping Standards: The following standards shall be adhered to:
- a. The landscaping requirements described in Section F. of this Ordinance shall be located on the street side of all walls, barriers, fences and other screening.
  - b. All areas not paved shall be screened by landscaping from public view with shrubs or trees and be properly sodded or seeded. All earthen areas shall be protected from erosion.
  - c. Landscaped yard areas may include the use of flagpoles, screens, terraces, fountains, pools and other water arrangements, and various types of trees and shrubs. All trees, plants and shrubs shall be varieties that are adaptable to the local soil and climate condition and which blend with existing natural growth and shall be compatible with adjacent landscaped areas, in the opinion of a qualified landscape architect or horticulturist.
- (1) One street tree (Maple, Oak, Honeylocust, etc.) shall be in place or planted for each fifty (50) feet of property abutting a public right-of-way. Trees shall be in place or planted adjacent to or in the right-of-way (depending on the location of utility easements).

- (2) One small flowering tree (Dogwood, Crabapple, Hawthorn, etc.) or tall deciduous tree (Maple, Oak, Honeylocust, etc.) shall be in place or planted for each one hundred (100) feet of building perimeter. These trees shall be located in the landscaped areas of the site.
- (3) One small flowering or tall deciduous tree shall be in place or planted for each twelve (12) parking spaces. These trees shall be planted adjacent to the parking areas.
- (4) The use of shrubs, additional trees (evergreen, deciduous and small flowering), annuals, perennials, spring flowering bulbs, and ground covers shall be at the owner's option.
- (5) Minimum size plants which shall be counted in meeting the requirements of (1), (2), and (3) are as follows:

Street or tall deciduous tree: 1-1/2" trunk diameter 1'-0" above-ground line. Small flowering tree: 4'-5' plant.

- (6) The owner is encouraged to keep as many of the existing trees on the site as possible.
  - (7) The owner may elect to treat portions of the site as natural landscaping; by encouraging the growth of native plants. Plants which can become a nuisance (Japanese Honeysuckle, Multiflora Rose, Autumn Olive, etc.) shall not be planted or maintained on the site unless a part of designated wetlands.
- d. All landscaped areas shall be perpetually maintained and in good condition at all times.
  - e. Landscaping devices shall not obscure the site distances in a manner that may create a traffic hazard nor should they obstruct fire access under paragraph 6, Fire Protection.

5. Utility Standards:

- a. Electrical and telephone service may be brought into the park overhead but shall be brought underground into the individual sites and to the buildings from the nearest available source with the exception of rail-served buildings where overhead service may be permitted. The purchaser or lessee will be responsible for the cost of such underground service. Pad-mounted electrical transformers or pad mounted accessories shall be located and screened so as to prevent viewing from any public street or adjacent property.
- b. Any Industrial Park District developer shall provide an adequate water supply for both industrial and fire protection use by service from the City of Erie. The water supply and system shall be constructed in conformance with the specifications and requirements of the supplier.

6. Fire Protection Standards:

- a. All permitted uses must conform to the Fire Prevention Code currently in effect in the City of Erie.
7. Erosion and Sedimentation Control: Prior to any earthmoving activities, developer shall prepare an Erosion and Sedimentation Control Plan which shall meet the standards of Chapter 102 (Erosion Control) of Title 25 Rules and Regulations of the Pennsylvania Department of Environmental Resources and shall be reviewed and found adequate by the Erie County Conservation District.
8. Any property within an Industrial Park District that abuts Presque Isle Bay between the center line of Cranberry Street and the center line of East Avenue shall meet the public access requirements as set forth in Article 3, Section 306 of the City of Erie Zoning Ordinance. The public access shall be considered a required conditional use and shall be approved by City Council after recommendation by the City Planning Commission and a public hearing as set forth in the PA Municipalities Planning Code, Act 170 of 1988.

## ARTICLE 3 - GENERAL REGULATIONS

### 301 NONCONFORMING USES AND NONCONFORMING STRUCTURES:

All uses, lots and structures that do not conform to the current zoning regulations of the district in which they are located, and which were lawful when they were first established, shall be known as “non-conforming” and shall meet the regulations of this Article. Uses, lots and structures that were not lawful when they were first established, or that changed in an unlawful manner, shall not have the right to continue, and shall be brought into conformance with this Ordinance. The following provisions shall apply to all legal nonconforming uses and legal nonconforming structures:

**301.10 NONCONFORMING USES OF LAND:** The lawful use of land existing at the time of the enactment of this Ordinance, or of an amendment thereto, not involving any principal and/or accessory structure, although such use does not conform to the provisions of this Ordinance, may be continued, provided that no such nonconforming uses of land shall in any way be expanded, extended, or moved in whole or in part to any other portion of the lot of record. If such nonconforming use of land or any portion thereof is discontinued or changed, any future use of such land shall be in conformity with the provisions of this Ordinance.

**301.20 NONCONFORMING USES OF STRUCTURES:** The lawful use of a structure existing at the time of the enactment of this Ordinance, or of an amendment thereto, although such use does not conform to the provisions of this Ordinance, may be continued and such use may be extended throughout the building provided that such extension of use does not displace a use conforming to the district designated by this Ordinance.

In any district (except as noted below), a lawful nonconforming use may be changed to a Permitted Use, a Special Exception or a Conditional Use for that district. In any “R” District, the lawful nonconforming use of a structure may also be changed to a Permitted use, Special Exceptions or Conditional Uses, as set forth in the RLB District, except a nonconforming residential use, may not be changed to any nonresidential use. This provision does not apply to nonconforming uses of structures in a W-R District.

**Expansion of Nonconforming Use:** A lawful nonconforming use shall only be expanded if it does not exceed a 50% maximum increase, in aggregate, over the entire life of the nonconformity. For example, if a building permit is issued for a 10 % expansion one year, and a 35% expansion of the original size 7 years later, any further requests for a permit for an expansion above 5% of the original non-conformity would be denied. Any expansion of a nonconforming use shall meet all required setbacks and all other requirements of this ordinance. No new nonconformity shall be created.

Whenever a nonconforming use of a structure, or a portion thereof, has been abandoned it shall not again be used except in conformity with the regulations of the district in which such structure is located.

A change from one nonconforming use to another nonconforming use may be permitted by the Zoning Officer with notice of this determination to be posted conspicuously on the property and written notice to be provided to adjoining property owners. The change of use must adhere to the following guidelines. : 1) the same general type of use is involved, 2) the operator of the new establishment agrees in writing as a condition of the permit to abide by any applicable conditions that were established for the previous use of the property, 3) the new use involves similar or less intensive characteristics compared to the previous use, 4) the new use does not involve the sale of alcohol unless the previous use also involved the sale of alcohol in a similar manner. All requests for other use changes shall be referred to the Zoning Hearing Board.

**301.30 NONCONFORMING STRUCTURES:** A structure existing at the time of the enactment of this Ordinance or of an amendment thereto, although such structure does not conform to the lot and yard requirements of this Ordinance, may be continued in use. If such nonconforming structure should be destroyed by any means a permit for its reconstruction shall be issued provided application for permit for reconstruction within the existing building envelope is made within three (3) years from date of such destruction.

Nonconforming accessory structures may be reconstructed, and increased up to 24% in size up to 720 square feet in size, without any time consideration. Proof of pre-existing structure will be required prior to a permit being issued.

**302 OFF-STREET PARKING** Off-street parking spaces shall be placed in such a manner that ensures ingress/egress to the City street system without disturbing other designated off-street parking spaces. Size of Parking - The following schedule of parking space and layout standards shall apply to all parking facilities provided in the City of Erie, in accordance with this Ordinance.

Angle of Parking Row to Driveway Aisle

	<u>30°</u>	<u>45°</u>	<u>60°</u>	<u>90°</u>
Depth of Parking Row	17'	19'	20'	18'
Width of Parking Space	9'	9'	9'	9'
Width of Aisle	11'	13'	18'	24'

Parallel parking spaces shall be at least twenty (20) feet in length and nine (9) feet in width (see illustration).

Parking garages and ramps shall adhere to all yard requirements in those districts where they are allowed. In addition, they shall submit a plan for vehicular ingress and egress to the City of Erie Department of Engineering (Traffic Engineer). This plan must be approved prior to the issuance of any permits required by this Ordinance.

Off-street parking spaces shall be provided for any new use hereafter established or for the enlargement to any existing use as follows:

<u>USE</u>	<u>PARKING SPACES REQUIRED</u>
Dwellings	1 per family living unit
Churches/ Stadiums/Convention Halls	1 per 5 seats in principal assembly room, if row seating, 1 per every 20 feet of row.
Schools	1 per classroom, plus .25 for each planned student over the age 16
Dormitories, Fraternities, Sororities, Hospitals, Nursing/Convalescent Homes	1 per 4 beds
Private Clubs, Eating and Drinking Places Theaters	1 per every 4 seats provided
Commercial Recreation, Retail Business, Personal Services, Neighborhood Center	1 per 350 square feet of floor area
Wholesale, Large Item Retail Sales (Lumber, Bedding, Carpet)	1 per 600 sq ft of floor area
Bowling Alleys	5 per bowling lane
Funeral Homes	10 per viewing parlor, but in no event less than 20 spaces.
Professional Services, Commercial Services, Office, Research Laboratories, Banks, Medical Clinics, Day Care Center, Public Library, Museum Community Center, Art Gallery	1 per 500 square feet of floor area
Manufacturing	1 per 3 employees on max working shift
Automotive Sales	One customer parking place for each 20 cars for sale
Gasoline Service Station	1 per bay plus one for every 2 employees
Hotels, Motels, Tourist Homes, Room/ Boarding Homes, Bed and Breakfast	1 per rentable unit
Marinas	1 per 2 boat stalls

Laundromat	1 per 6 washing machines
Fitness Center, Gym	1 per 200 sq ft of floor area accessible to customers, plus 2 spaces per court

NOTE :Refer to Article 2, Section 206 for all I.P. Manufacturing Park District regulations.

Where the use of the premises is not specifically mentioned, the requirement for similar uses shall apply. If no similar uses are mentioned, the parking requirement shall be one (1) space for each two (2) proposed patrons and/or occupants of that structure.

Properties in the C-3, zoning district shall not be required to provide off street parking places. Properties in the W-C-2, W-C-3 and C-4 zoning district shall be required to provide fifty percent (50%) of the off street parking places required above.

Change of Use: If a use is legally changed to another use, the new use will not be required to provide additional parking.

Mixed Uses: In the case of mixed use buildings, the parking facilities required shall be the sum of the requirements for the various individual uses, computed separately in accordance with the parking requirements of this Article.

Location of Parking: Non-Residential Parking may be located on other off-street property than the lot which the principal use is on, provided that all such spaces lie within 500 feet of a pedestrian entrance to such principal use. Residential parking must be on the same lot or a lot which directly abuts the residential use, if under the same ownership.

**303 SIGNS:** No sign shall state or imply that a property may be used for a purpose prohibited by this ordinance. Signs advertising a use no longer in existence or a product no longer available shall be removed or changed to advertise the new use within six (6) months after the cessation of the original use or sale of product.

All signs, billboards, outdoor advertising, or exterior graphic displays shall require a building permit and shall conform to the following standards:

**303.10** In “R-1”, "R-1A", "R-2", "R-3" and "W-R Districts a non-illuminated, non-reflective sign not exceeding four (4) square feet in area is permitted attached to the building or mounted not over six (6) feet high on an ornamental pole in the front yard announcing the name and address of the occupant of the premises on which said sign is located.

**303.11** An identification sign not exceeding twenty-four (24) square feet in any "R" or "W-R" District is permitted in connection with any church, school, college, hospital, institution, park, playground, or other similar public or semi-public use.

**303.12** In “RLB” and “C-4” Districts, identification signs advertising the occupant's commercial, industry or products made or sold on the premises are permitted not exceeding twenty-four (24) square feet for each seventy-five (75) feet of frontage or portion thereof. Signs for those lots with less than seventy-five (75) feet of frontage are limited to twenty-four (24) square feet.

**303.13** In "C-1", "W-C", "M-1" and "W-M" Districts, signs attached to buildings shall not extend over two (2) feet above the roof line of the building at the exterior wall. The sign must also comply with the height requirements of Section 205.

**303.14** In C-1, C-2, C-3, M-1 and M-2 Districts, all signs within fifty (50) feet of any "R" or "W-R" District shall be limited to identification signs advertising the occupant's commercial, industry or products made or sold on the premises and shall not exceed ten percent (10%) of the surface of the wall on or in front of which the sign is mounted. All identification signs over fifty (50) feet from any "R" or "W-R" District shall not exceed in square feet 2 times the lineal feet of frontage of the lot. If there is more than one business on the lot, the lineal feet of lot frontage shall be divided accordingly

**303.15** Temporary signs not exceeding six (6) square feet for the sale of individual properties and not exceeding thirty-two (32) square feet for identifying residential development, developers, contractors, and/or realtors are permitted in "R," "W-C," "W-M," and "W-R" Districts while property is under construction or offered for sale and they shall be removed within ten (10) days of the date of the final sale of the property.

**303.16** Lights of illuminated signs shall be shielded to prevent the lights from shining directly into traffic upon public streets or directly into nearby dwellings. No flashing, moving or on and off style or rotating beacon style lights will be permitted. This provision shall not restrict signs with electronic changing messages that do not flash.

**303.17** In all W-C, and W-M Districts, all signs shall be limited to identification signs advertising the occupant's commercial, industry or products sold on the premises and shall not exceed ten percent (10%) of the surface of the wall on or in front of which the sign is mounted.

**303.18** No outdoor advertising and portable signs shall be permitted in any Waterfront District.

**303.19** All signs shall be located in such a manner that pedestrian and/or vehicular traffic view will not be obstructed. Any sign located less than 10 feet from the right-of way of a street shall have a minimum clearance of 7 feet above the ground level or shall not exceed 30 inches in height. Any sign constructed on a corner of two intersecting streets and placed within the clear sight triangle shall be less than 30” or more than 7 feet in height.

**303.20** Identification signs for nonconforming uses located in residential districts shall be limited to the size requirement established for RLB District as set forth in Section 303.12. Permanent signs for a residential developments containing 10 or more residential units shall not exceed 32 square feet, unless otherwise permitted in that district.



**303.21** All outdoor advertising located along the Bayfront Parkway and Eastside Connector lying in "C-2," "M-1," "M-2," and "C-3," Zoning Districts shall be set back six hundred (600) feet from the center line of the Bayfront Parkway and Eastside Connector. For purposes of this Section, "Bayfront Parkway and Eastside Connector" is defined as an area consisting of the Parkway/Connector right-of-way beginning at the intersection of West 8th Street and the Bayfront Parkway and traveling generally eastward along the Bayfront Parkway/Eastside Connector to its eastern terminus point near East 38th and Bird Drive.

**303.22** Along the corridor designated as the Seaway Trail, which includes West 6<sup>th</sup> Street, East 6<sup>th</sup> Street, East Lake Road, Cranberry Street from West 6<sup>th</sup> Street to the Bayfront Parkway, the Bayfront Parkway from Cranberry Street easterly to the Eastside Connector, and the Eastside Connector from the Bayfront Parkway to East 6<sup>th</sup> Street, no outdoor advertising devise, as defined, may be erected by any owner, person responsible or other person:

- A. Within 600 feet of the nearest edge of the right-of-way; or
- B. More than 660 feet from the nearest edge of the right-of-way if the sign is visible from the main-traveled way and the purpose of the sign is that its message be read from the main-traveled way, except as follows:
  - (1.)The official signs and notices which are required or authorized by law and which conform to the national standards promulgated by te Secretary of Transportation of the United States pursuant to 23 U.S.C. Section 131 (Relating to control of outdoor advertising);
  - (2.)Outdoor advertising devises advertising the sale or lease of the real property upon which they are located;
  - (3.)Outdoor advertising devices advertising activities conducted on the property on which they are located, including devices which display a message that may be changed at reasonable intervals by electronic process or remote control; and
  - (4.)Directional signs, including, but not limited to, signs pertaining to natural wonders, scenic and historical attractions and other points of interest to the traveling public which conform to the national standards promulgated by the Secretary of Transportation of the United States pursuant to 23 U.S.C. Section 131.

**303.23** All outdoor advertising devices constructed and existing on the effective date of this Ordinance, which would be prohibited under this Ordinance, shall be permitted except that if the devise shall not be used for advertising for a period of more than one year or shall become dilapidated, the devise shall be removed.

**303.24** If the Seaway Trail corridor is designated as a Byway by the Commonwealth of Pennsylvania, Department of Transportation, the Municipality shall enforce the prohibitions set forth in this Ordinance and shall not revise this Ordinance without the prior written approval of the Department. Failure to do so may result in revocation of the Byway designation.

**303.25** All outdoor advertising shall be located in any C-2, C-3, M-1 or M-2 zoning district and shall conform to the lot, yard, and height requirements as established in Section 205. All outdoor advertising shall not exceed six hundred seventy-two (672) square feet in size and shall be mounted at least ten (10) feet from the ground unless mounted flush on the surface of a building wall. An allowance for extensions/embellishments is permitted. Such extensions/embellishments shall not exceed more than a ten percent (10%) addition to the allowable sign area. Outdoor advertising signs shall be spaced a minimum of one thousand (1,000) feet from any other outdoor advertising sign.

**303.26** Portable signs shall only be permitted on non-residential property in a commercial or manufacturing district and if they comply with the following: All portable signs shall require a building permit, and shall be permitted for a up to four (4) periods of 15 consecutive days during the calendar year. Portable signs can be located anywhere on a property, with the exception of the public right-of-way, a clear sight triangle, or on required parking spaces. Portable signs shall not exceed 6 feet in height or 32 square feet. Any electrically operated sign shall conform with and require a City of Erie Electrical Permit.

**303.27** Temporary signs. Signs which are visible on the exterior of a structure shall be considered as identification signs and are restricted to the total square footage allowed by Section 303 of this ordinance. Temporary signs in conjunction with an event shall be allowed not more than three (3) times a year. Each event will be limited to a 24 square foot sign to be displayed for not more than 7 days prior and three days after the event.

**303.28** Prohibited Signs: Signs are prohibited which simulate official, directional or warning signs erected or maintained by the Federal, State or City governments, a railroad, a public utility or similar agency concerned with the protection of public health or safety.

**303.28** Routine non-advertising signs, situated within the property lines not exceeding 4 square feet in area, such as signs stating "No Trespassing" or "Private Drive", entrance and exit directional signs shall be permitted.

#### **304 TEMPORARY STRUCTURES AND STORAGE:**

**304.10** Temporary structures used in conjunction with construction work shall be permitted only during the period that the construction work is in progress. Permits for temporary structures shall be issued for a six-month period. Temporary occupancy of cellars or other foundation structures as dwellings before completion of the total structure shall not be permitted.

**304.20** The trailer portion of a tractor-trailer combination may be used for storage in the M-1 and M-2 Manufacturing Districts. Such use shall not infringe on required yard space nor exceed lot coverage requirements (see Section 205). Such use must comply with all lot, yard and height requirements (see Section 205).

### **305 CONDITIONAL USES, SPECIAL EXCEPTIONS AND SPECIAL REGULATION**

**CRITERIA:** The criteria for Conditional Uses, and Special Exceptions as well as general special restrictions on various uses are listed in this section. In addition to these, the Zoning Hearing Board, in granting Special Exceptions, and City Council/Planning Commission in considering Conditional Uses, are charged with considering the effect that such proposed uses will have upon the immediate neighborhood. The preservation and integrity of existing development must be carefully weighed and given priority in each decision. In granting a Special Exception or Conditional Use, the Board or Council (as appropriate) may attach reasonable conditions and safeguards, in addition to those expressed in this Ordinance, as it may deem necessary to implement the purposes of the Pennsylvania Municipalities Planning Code and of this Ordinance. This section also contains specific criteria for permitted uses of the City's Zoning Ordinance.

**305.01 Group Home Special Exception:** Designed as a reasonable accommodation of group living arrangements for handicapped persons as defined by the Fair Housing Act, 42 U.S.C. 3601 et seq., so long as the facility abides by all City codes of general applicability and does not pose an undue hardship on, or fundamental alteration in the nature of the zoning ordinance.

**305.10 Automobile Related Uses: Plans for Off-Street Parking Lots, Drive-In Commercial, Gasoline Service Stations, and Service Garages** shall show the location of all the buildings and/or structures upon the lot, the location of driveways, the location of screen planting strips, and all appropriate dimensions.

**305.11 Off-Street Parking Lots and Accessory Parking:** If located adjacent to properties in "R" Districts not served by subject lot, a screen planting strip shall be installed and suitably protected from automobiles by wheel barriers or guard rails. Screen Plantings shall also be provided along any road frontage in all districts with the exception of "C-3", "C-4" and "M" Districts. All public sidewalks along street property lines except at driveways shall be protected from automobiles extending on or over them by wheel barriers or guard rails. Lots five thousand (5,000) square feet or larger shall be surfaced with asphalt or concrete. Lots under five thousand (5,000) square feet in size shall use gravel, crushed limestone or a similar treatment; however, the treatment shall result and be maintained in a mud and dust-free surface.

**305.12 Drive-In Commercial and Gasoline Service Stations** shall be located at least two hundred (200) feet from the nearest property line of any school, park, playground and at least one hundred (100) feet from the nearest property line of any hospital, church, or public library to the nearest property line of said drive-in commercial or gasoline service station; the buildings, pump islands and other equipment shall be at least fifty (50) feet from any "R" District and excepting Service Garages fifteen (15) feet from any street property line. Service Garages shall be at least twenty (20) feet from any property line which the garage doors face.

A screen planting strip shall be provided adjacent to properties in "R" Districts and it shall be suitably protected from automobiles by wheel barriers or guard rails. All public sidewalks along street property lines except at driveways shall be protected from automobiles extending on or

over them by wheel barriers or guard rails. The site shall be surfaced with asphalt or concrete aprons at pump islands and concrete driveways between street property lines and curb lines. All lights shall be shielded to protect adjacent properties in "R" Districts from glare.

**305.13 Stacking Requirements for Drive-In, Drive Through Facilities:** This section provides vehicle stacking standards for drive-in, drive-through facilities. These may include such uses as banks, fast-food restaurants and car washes. The purpose of these standards is to provide minimal stacking capacity for various uses so vehicles will not use public streets while queuing in line for service. All references to stacking capacity relates to typical automobiles. A length of twenty (20) feet per auto will be used to accommodate one (1) vehicle and minimal head space. Minimum stacking lane width is nine (9) feet.

<u>Use</u>	<u>Stacking Capacity Per Drive-In Window</u>
Restaurant	4* per drive-in window
Bank	3 per drive-in window
Car Wash	2 per wash bay
Gas Stations	2 per pump

\*If there are separate order and pickup windows, two (2) for each shall be accepted.

For other uses, guidelines from the Institute of Traffic Engineers may be used or the written recommendations of a professional engineer.

Note: Stacking capacity is to be measured from the lot line to the service window and is not to include any area of the public right-of-way.

**305.14 Truck Terminals:** The areas for vehicle storage and maneuver in truck terminals shall be paved.

**305.15 Cemeteries** are permitted in "R-1" and "R-2" Districts only as the extension of an existing cemetery or to preserve a "Burying Ground."

**305.16 Fraternities, Sororities and Dormitories:** Such uses are often intense residential uses that are also sometimes used for social gatherings. As such, these uses can be highly intrusive in a residential neighborhood and the following conditions must be met:

- a. Required lot size is ten thousand (10,000) square feet.
- b. Side yards must be fifteen (15) feet each, front yards thirty-five (35) feet and rear yards forty (40) feet.
- c. One off-street (1) parking space per four (4) residential occupants shall be required plus an additional five (5) off-street spaces for visitors. All parking must be on lot.
- d. Side and rear yards which abut residential uses shall provide screen planting.

e. No outdoor loud speakers or sound systems will be allowed.

f. Refuse receptacles (i.e., "dumpsters" et. al.) shall be located behind the rear of the main building, shall be screened on three sides.

**305.17 Fire Stations and Other Municipal Buildings** in “R-1A”, "R-1," "R-2" and "R-3" Districts shall be located upon lots facing streets designated as major thoroughfares in the Major Thoroughfares Plan.

**305.18 Rooming and Boarding Houses:** Rooming and boarding houses shall be allowed as a Special Exception in the R-3 District if they meet the following conditions:

a. No more than six (6) roomers/boarders may be housed.

b. Each roomer/boarder shall have an off-street, on-site parking space.

c. The owner or leaser of the residence shall reside full time on the premises.

**305.19 Utility Substations** in the required front yard or public right-of-ways shall be constructed below the grade of the adjoining ground. Installations above ground shall comply with lot and yard requirements and shall be housed in a structure with an architectural design, exterior material and appearance harmonizing with the adjacent dwellings.

**305.20 Churches, Hospitals, Places of Worship and Schools:**

a. Shall provide all parking and loading/unloading requirements as required by this Ordinance.

b. All parking and recreation/play areas which abut residential uses shall be screened.

c. Any outdoor lighting shall be designed to prevent glare to adjoining properties.

**305. 21 Townhouse Developments:**

a. The developer may vary architectural treatments between units in a townhouse development. Variations may include those of exterior elevation, building setbacks, provision of balconies, architectural details, pitch of roof, exterior materials or use of color.

b. Variety and flexibility in design, layout and arrangement of buildings, parking areas, services, recreational areas, common open space, and planting that fully considers the particular physical characteristics of the site and natural amenities is highly desired.

c. Access and service shall be provided in the front of each dwelling unit in the townhouse. Parking will be provided on the lot, as carports, as an integral part of the townhouse, or a joint parking facility for a group of townhouses with such deed restrictions as are necessary to determine ownership and maintenance of common parking facilities and methods of assigning charges for maintaining snow removal and repairs.

d. Adequate refuse storage facilities shall be provided and shall be either in a structure closed on at least three (3) sides, or shall be screened from adjoining properties by a fence or screen plantings.

**305.22 Bed and Breakfast:** Such uses are intended to provide overnight or short-term [not more than two (2) weeks accommodations for transient guests in a home-like atmosphere. They must meet the following regulations:

a. No signs in excess of six (6) square feet shall be allowed. Only one such sign shall be permitted.

b. No more than twelve (12) guest rooms will be permitted.

c. One (1) off-street parking space for each guest room shall be required.

d. Shall conform to the definition of “bed and breakfast homestead or inn” as set forth by the Pennsylvania Public Eating and Drinking Place Law, as amended.

**305.23 Day Care Centers:** Day Care Centers (see Article 6) shall be allowed as a Special Exception providing the following criteria are met:

a. Any outdoor play area shall be effectively screened from abutting properties.

b. For all new construction, and where feasible for existing structures, circular driveways or the equivalent shall be provided to deliver and pick up children off public streets. These facilities are intended for the safety of the children and the protection of the neighborhood. In any event, the developer shall demonstrate how pick up and delivery shall occur in a safe manner.

c. Such facilities must be licensed or registered (as appropriate) by the Pennsylvania Department of Public Welfare.

### **305.24 Multiple Family Dwellings**

- a. In R-2 Districts, 3 and 4 family dwellings are permitted provided each dwelling has at least two thousand (2,000) square feet of lot area per family. (80-1990)
- b. In "R-3," "RLB-1," "C-1," "C-2," "C-4", "W-C" and "W-R" Districts, Multiple-Family Dwellings shall comply with the yard requirements for an "R-3" District and the minimum lot area per family established in Section 205.

**305.25** Reserved for future use

**305.26** Reserved for future use

**305.27 Outside Storage:** The outdoor storage of any equipment or materials associated with any commercial or manufacturing use, regardless of the zoning district it is located in shall be completely screened from view.

**305.28 Personal Care Boarding Home for Adults:** The purpose of such homes is to provide residences for individuals in a home-like setting. Consequently, it is essential to maintain an exterior appearance that is in harmony with surrounding residences. In addition, such uses shall meet the following conditions:

- a. There shall be no sign or exterior display indicating the name of the home or its use larger than four (4) square feet.
- b. At least one (1) additional on-lot parking space shall be provided for each two (2) guests, along with one (1) space per employee.
- c. No home shall admit more than eight (8) guests/clients at any one time.
- d. Evidence of any required county and/or state certifications shall be presented to the Zoning Officer.

**305.29 Libraries and Museums:** Such uses will be allowed in RLB District if their total floor area does not exceed seven (7,000) square feet.

**305.30 Continuing Care Retirement Communities:** These facilities are generally campus-like in design and at a large physical scale. They typically include residential units, assisted care units and nursing home beds designed to serve an older population.

- a. The developer shall certify that all units will meet the federal standards for housing for the elderly. Specifically, all residents shall be sixty-two (62) years of age or older or at least fifty-five (55) years of age for one (1) resident of no more than eighty percent (80%) of the units. In lieu of this, certification by the Continuing Care Accreditation Commission will be acceptable.

- b. The development shall meet parking and density requirements for all components contained within the development.
- c. Any outdoor lighting shall be designed to prevent glare to surrounding properties.
- d. The development shall be effectively screened from abutting residential properties with a mixture of deciduous and coniferous plantings sufficient to filter most light and noise throughout the year. At a minimum, this screen/buffer should be at least six (6) feet in height and ten (10) feet in width within two (2) years of planting.
- e. A development plan is required.
- f. All side yards shall be at least twenty (20) feet, all rear yards at least forty (40) feet.

**305.31 Corporate Offices and Research Laboratories:** Corporate Offices and Research Laboratories in "RLB-1," "C-1," "C-2" and "C-3" Districts shall not include pilot plants for the production or manufacture of goods or materials, and the laboratory areas shall be completely sealed and air controlled to prevent any direct emission of smoke or fumes to the outside.

**305.32 Medical and Dental Clinics:**

- a. All required parking, loading and unloading shall be contained entirely on-lot, including sufficient maneuvering room so that vehicles will not back onto a public street. Any parking area next to a residential use shall be screened.
- b. All lighting shall be so arranged to prevent glare to adjoining properties.

**305.33 Nursing and Convalescent Homes:**

- a. Shall provide all parking and loading/unloading requirements as required by this Ordinance.
- b. The design and landscaping shall be compatible with, and preserve the character of adjoining residential uses.
- c. All parking and recreation/play areas which abut residential uses shall provide screen planting.
- e. Any outdoor lighting shall be designed to prevent glare to adjoining properties.
- f. Such uses shall have, and present, all needed local, county, state or federal permits. Final approval of all needed permits shall be required.



**305.34 Neighborhood Centers:** These facilities are designed to provide a variety of services to residents within their area. They shall meet the following additional standards:

- a. Side yards shall be at least twenty (20) feet in width.
- b. The parking area shall be calculated by combining the requirements for each use/service to be offered by the center. However, in no event shall it be less than one (1) per each three hundred fifty (350) square feet of floor area.

**305.35 Greenhouses/Nurseries:**

- a. Side yards which abut residential users or "R" Districts shall be at least fifteen (15) feet in width.
- b. Customer parking shall be accommodated on-lot.

**305.36 Funeral Homes:** All Funeral Homes shall provide:

- a. Adequate parking on site for at least twenty (20) parking spaces for visitors (see also Section 302).
- b. All pickup and delivery shall be accommodated on site.
- c. Lighting shall be directed away from abutting properties.

**305.37 Animal Care** shall be totally enclosed in a sealed, air conditioned structure at least one hundred (100) feet from the nearest dwelling when located in a "C-2" District.

**305.38 Light Manufacturing** in a "C-3" District shall not occupy fifty percent (50%) of the ground floor area and at least fifty percent (50%) of the goods produced shall be sold at retail on the premises.

**305.39 Mobile Homes and Trailer Sales Lots** in a "C-2" District shall be located upon lots adjoining an established Drive-In Commercial, Gasoline Service Station, Service Garage, or Automobile Sales.

**305.40 Commercial Uses Similar to Permitted Uses** in "C-2" and "C-3" Districts Not Otherwise Specified shall be referred to the Zoning Hearing Board for interpretation and approval.

**305.41 Adult Book Store, Adult Live Entertainment, an Adult Motion Picture Theater, an Adult Mini-Motion Picture Theater, or a Massage Parlor** shall be located at least seven hundred fifty (750) feet from the nearest property line of any other adult book store, adult motion picture theater, adult mini-motion theater, or massage parlor and shall be located at least seven hundred fifty (750) feet from the nearest property line of any

residential area, church, school, other institution of learning or education, hospital, library, park or playground.

**305.42 A Bottle Club** shall be located at least one thousand (1,000) feet from the nearest property line of any residential district, church, school, other institution of learning or education, hospital, library, park or playground.

**305.43 Convenience Stores:**

- a. Fuel pumps shall meet the requirements found in Sections 305.12 and 305.13. Fuel pumps shall not be allowed at stores located in the RLB or C-4 Zoning Districts.
- b. Stores in the RLB or C-4 Zoning Districts shall not exceed 2,500 square feet in size and shall not have fuel pumps.
- c. Any lot line abutting a residential use or district shall provide appropriate screening.
- d. Any outdoor mechanical or refrigeration equipment shall be muffled to minimize noise.

**305.44 Limited Retail Commercial:** The intent of this provision is to accommodate small-scale retail enterprises benefiting nearby residents and attracting outside visitors.

- a. Total commercial use size shall not exceed seven thousand (7,000) square feet in floor area.
- b. A use shall meet parking provisions for its commercial type.
- c. There shall be no outdoor sound transmission systems or displays of any sort except as allowed by this Ordinance.

**305.45 Communication Towers/Antennas:** Communication towers and ancillary equipment may be installed only in the C-3 District, the M-1 or M-2 Districts in accordance with the height and setback requirements of the applicable zoning districts (8/09) and with the following regulations:

- a. Antennas mounted on an existing public utility tower, existing building or other existing structure shall be treated as a permitted use subject to the conditions of Section 305.45(b). Separate stand-alone towers constructed new shall be treated as Special Exceptions and referred to the Zoning Hearing Board for review and approval under Section 305.45(c).

b. Regulations Governing Communications Antennas and Communications Equipment Buildings: Building mounted Communications Antennas shall not be located on any single-family dwelling or two-family dwelling.

Omnidirectional or whip communications antennas shall not exceed twenty (20) feet in height and seven (7) inches in diameter.

Directional or panel communications antennas measure in length by width no more than fifteen (15) square feet in area, however may not exceed eight (8) feet in length. (8/09)

A communications equipment building shall be subject to the height and setback requirements of the applicable zoning district for an accessory structure.

The owner or operator of communications antennas shall be licensed by the Federal Communications Commission to operate such antennas.

c. Standards for Communications Towers as Special Exceptions: The applicant shall demonstrate that it is licensed by the Federal Communications Commission to operate a communications tower, if applicable, and communications antennas.

Access shall be provided to the communications tower and communications equipment building by means of a public street or easement to a public street. The easement shall be a minimum of twenty (20) feet in width and shall be improved to a width of at least ten (10) feet with a dust-free, all weather surface for its entire length.

A communications tower may be located on a lot occupied by other principal structures and may occupy a leased parcel within a lot meeting the minimum lot size requirements for the zoning district.

The applicant shall demonstrate that the proposed height of the communications tower is the minimum height necessary to perform its function.

The foundation and base of any communications tower shall be set back from any Residential District at least one hundred (100) feet and shall be set back from any other property line (not lease line) at least fifty (50) feet.

The base of a communications tower shall be landscaped so as to screen the foundation and base and communications equipment building from abutting properties.

The communications equipment building shall comply with the required yards and height requirements of the applicable zoning district for any accessory structure.

The applicant shall submit a copy of its current Federal Communications Commission license; the name, address and emergency telephone number for the operator of the

communications tower; and a Certificate of Insurance evidencing general liability coverage in the minimum amount of two million dollars (\$2,000,000) per occurrence and property damage coverage in the minimum amount of one million dollars (\$1,000,000) per occurrence covering the communications tower and communications antennas.

All guy wires associated with guyed communications towers shall be clearly marked so as to be visible at all times and shall be located within a fenced enclosure.

The site of a communications tower shall be secured by a fence with a minimum height of six (6) feet to limit accessibility by the general public.

No signs or lights shall be mounted on a communications tower, except as may be required by the Federal Communications Commission, Federal Aviation Administration or other governmental agency which has jurisdiction.

If a communications tower remains unused for a period of twelve (12) consecutive months, the owner or operator shall dismantle and remove the communications tower within six (6) months of the expiration of such twelve (12) month period.

One off-street parking space shall be provided within the fenced area.

305.45.5 Communication Towers/Antennas: Communication towers, antennas and ancillary equipment may be installed in all districts with the exception of those listed in Section 305.45 in accordance with the following regulations as approved by the Zoning Hearing Board of the City of Erie, or in Waterfront Zoning Districts by City Council.

(a) There are no existing, approved or proposed wireless communications towers or other structures which are reasonably available to accommodate the wireless communications equipment planned for the proposed tower in order to provide the service which the proposed tower would provide.

(b) The size and height of the tower is the minimum necessary for the purpose; provided, however that the tower height, including any appurtenant equipment and devices shall not exceed seventy-five(75) feet and in no event shall the tower be at such a height as to require lighting.

(c) The tower and its accessory structures have been designed in all respects to accommodate multiple users to the extent which it can be done without impact on the neighborhood, and the applicant has agreed to permit other service providers to co-locate on the tower with commercially reasonable terms.

(d) The tower and its accessory structures have been sited as to minimize the effect of the tower upon the neighborhood. The tower and all appurtenant equipment and

structures shall meet all setback requirements for the district in which it is located. (See Section 205)

(e) The tower and its accessory structures shall be installed using the latest technology of Stealth Design. Current examples of such designs include flag pole, church steeples and integration onto existing public utility poles. The tower and all accessory buildings have been designed to be as unobtrusive as possible, with all utility lines serving them installed underground and the use of the best available technology to minimize the noise emitted from the site.

(f) The applicant shall submit a copy of its current Federal Communications Commission license; the name, address and emergency telephone number for the operator of the communications tower; and a Certificate of Insurance evidencing general liability coverage in the minimum amount of two million dollars (\$2,000,000) per occurrence and property damage coverage in the minimum amount of one million dollars (\$1,000,000) per occurrence covering the communications tower and communications antennas.

(g) If a communications tower remains unused for a period of twelve (12) consecutive months, the owner or operator shall dismantle and remove the communications tower within six (6) months of the expiration of such twelve (12) month period.

(h) Neighborhood Information – Prior to the application of a Special Exception the owner or operator of the proposed communication antenna shall attend a pre-approval Planning Commission Conference and shall provide proof of a neighborhood involvement meeting regarding the placement of the proposed equipment. The range of the neighbor notification shall be within a 500 foot radius of the proposed equipment and antenna installation

**305.46 Car Washes:** Where a facility is located adjacent to or across the street from a “R” district, the facility shall not be open to the public between the hours of 10:00 PM and 7:00 AM. Any outdoor mechanical equipment shall be muffled to minimize noise.

**305.47 Heavy Manufacturing** shall be located where the emission of noxious gases, fumes, smoke or dust will not be objectionable to established permitted uses nearby or is controlled by the installation of special equipment. Outside storage yards abutting or immediately across a street from any "R" District shall be screened with a solid fence or wall facing the "R" District.

**305.48 Scrap Yards** shall comply with the following requirement:

a. All lots shall be at least two (2) acres in size and located at least three (300) hundred feet from any “R” or RLB District.

- b. There shall be no storage of scrap, machinery or equipment of any kind in areas visible from the surrounding properties or a public road.
- c. All yard spaces shall be at least fifty (50) feet.
- d. The processing or storage of hazardous materials as the same are defined by Department of Environmental Protection (DEP) shall not be permitted.
- e. The facility shall provide a fence around the premises at least eight (8) feet in height, constructed to block the line of sight and be set at least ten (10) feet back from any yard line.

**305.49** Any other manufacturing use which is not objectionable to immediate neighbors because of noise, vibration or emission of noxious gases, fumes or dust shall be referred to the Zoning Hearing Board for interpretation and approval.

**305.50** Correctional Facilities and Custodial Care Facilities shall comply with the following:

- (a) No such use shall be approved if located within 1,000 feet from another Correctional or Custodial Care Facility;
- (b) No such use shall be approved within 500 feet of a school, park, playground, church, community center, child care facility or other area where minor children assemble or congregate;
- (c) The density of development for any facility shall not exceed that authorized in Section 205 for the district in which it is located;
- (d) Commercial outdoor signs shall be prohibited;
- (e) Any additional conditions ensuring appropriate security measures, including, but not limited to fencing and other barriers, cameras, lighting, guards, sign-in and sign-out sheets, curfews for residents, guard dogs, sirens and direct alarms with the Police Department may be considered prior to approval;
- (f) The facility shall be designed to address the safety of those within and outside of the facility;
- (g) Walls, fences, and other physical barriers shall be designed to be compatible with the architecture of the facility;
- (h) There shall be no direct glare of any sort of lighting onto an adjoining property;
- (i) A written statement from the Chief of Police and Fire that the plan has been reviewed for the physical layout of the proposed facility. They shall also review the proposed operational plans (ie, Security and Fire Evacuation Plans) prior to the public hearing before City Council. Any additional security recommendations that either Chief may have should be included in this letter.

**305.51 Licensed Massage Therapy (8/09)**

- a. In order to perform massage therapy services, all individuals shall hold a degree or certificate with a minimum of 600 hours completed curriculum from a school licensed to teach therapeutic massage therapy techniques. By October 2010, all individuals shall hold a license from the State of Pennsylvania, in accordance with the Pennsylvania Massage Therapy Law, PA House Bill 2499 .
- b. Other licensed professionals performing massage services within their scope of practice – including licensed physicians, nurses, chiropractor, physical therapists, or trainers – are no required to obtain a massage therapist license.
- c. Existing practitioners are eligible provided they meet one of the following grandfather provisions of the PA Massage Therapist Therapy Law:
  - 1. Passed a certification examination accredited by the National Commission of Certifying Agencies
  - 2. Completed 500 hours of instruction in an approved education program and earned a certificate / diploma from that program
  - 3. Passed either (a) the NESL examination offered by the National Certification Board for Therapeutic Massage and Bodywork or (b) the Massage and Bodywork Licensure Examination offered by the Federation of State Massage Therapys, and has no less than 100 hours of instruction
- d. On October 7, 2010, all regulations of massage therapist under this ordinance shall be pre-empted and superseded by state law.

**305.52 WIND ENERGY CONVERSION SYSTEMS (WECS):** A WECS may be installed in the M-1, M-2, W-M and I-P Districts as a Conditional Use approved by City Council. Such approval shall be in accordance with the following requirements:

- a. The maximum height of a WECS shall be no taller than 160 feet in height.
- b. The minimum setback for a WECS shall be 1.1 times the total height from the nearest occupied building, property line, or public or private street right of way.

NOTE: The total height shall include the height of any structure that a tower or pole is mounted on if it is not mounted directly at ground level. The setback distance shall be measured from the center of the wind turbine base to the nearest point on the foundation of the occupied building.

- c. The following performance standards shall be met for all WECS:
  - 1. All wind energy systems including towers shall comply with all applicable local, state and national construction and electrical codes, and applicable electric utility standards.

2. No wind energy system shall be installed until evidence has been given to the City of Erie that the electric utility company has been informed of the customer's intent to install an interconnected customer-owned generator. Off-grid systems shall be exempt from this requirement.
3. An wind turbines shall be equipped with controls to limit the rotational speed of the rotor within the design limits of the turbine.
4. Wind turbines shall remain painted or finished with the non-reflective color that was originally applied by the manufacturer.
5. All signs, other than the manufacturer's or installer's identification, appropriate warning signs, or owner identification on a wind generator, tower, building, or other structure associated with a wind energy system visible from any public road shall be prohibited.
6. A clearly visible warning sign detailing voltage must be placed at the base of all pad mounted transformers and substations.
7. On-site transmission and power lines between turbines or other structures or buildings shall, to the maximum extent practicable, be placed underground.
8. Visible, reflective, colored objects, such as flags, reflectors or tape, shall be placed on the anchor points of guy wires and along the guy wires eight (8) feet from the ground.
9. Wind turbines shall not be artificially lighted unless the Federal Aviation Administration or other applicable authority regulating air safety requires such lighting.
10. All towers or poles shall be enclosed by an eight and a half (8.5) foot fence with a lockable entry to prevent entry by non-authorized persons. Or, the lot on which the towers or poles are located may be enclosed by an eight and a half (8.5) foot perimeter fence with a lockable entry, and all towers shall have clearance of at least ten (10) feet for any climbing structure (ladder rungs, etc).
11. The name and telephone number of the current contact person in the event of an emergency shall be posted at the site at all times.
12. The applicant shall maintain the wind energy system in good condition. Maintenance shall include, but not be limited to, painting, structural repairs, and security measures.
13. The owner and/or operator of a wind energy system, at all times, shall maintain a current general liability insurance policy covering bodily injury and property damage



caused by or arising from the wind energy system with limits of at least \$1 million per occurrence and \$1 million in the aggregate. A certificate of such insurance shall be supplied to the City of Erie prior to issuance of a permit and a current certificate of insurance shall be supplied to the City of Erie annually within thirty (30) days after the policy anniversary issuance date.

14. The facility owner and operator of a WECS shall maintain a telephone number and identify a responsible person for the public and the City of Erie to contact with inquiries and complaints throughout the life of the project. The facility, owner and operator shall make reasonable efforts to respond to inquiries and complaints by the public, and shall respond fully to all inquiries and complaints by the City of Erie.
- d. In addition to other requirements of this ordinance, an application for a permit shall meet the following submission requirements:
    1. A document providing a description of the proposed wind energy system shall include all of the following:
      - a. Property lines and physical dimensions of the property, including the locations of any existing structures on the property.
      - b. Location and height of each proposed wind turbine, setback distances, access road and turnout locations, substation(s), ancillary equipment, buildings and structures, including permanent meteorological towers, associated transmission lines and layout of all structures within the geographical boundaries of any applicable setback.
      - c. Any public road right of ways that are contiguous with the property and all utility lines or easements.
      - d. Wind system specifications, including manufacturer and model, rotor diameter, tower height and tower type (freestanding or guyed) and approximate generating capacity.
      - e. Stamped engineered drawings of the tower, base, footings, and/or foundation as provided by the manufacturer. Wet stamps shall not be required.
    2. An affidavit or evidence of agreement between lot owner and the facility's owner or operator confirming that the owner or operator has permission of the property owner to apply for necessary permits for construction and operation of the wind energy system.

3. Other relevant studies, reports, certificates and approvals as may be reasonably requested by the City of Erie including but not limited to documents confirming compliance with all setbacks and performance standards.
  4. Documents related to decommissioning, including a schedule for decommissioning and financial security to ensure such decommissioning.
- e. An applicant for a WECS shall hold a Neighborhood Informational Meeting prior to going before the City Planning Commission. The applicant shall notify all property owners within a 500-foot radius of the property lines of the lot upon which the WECS is proposed to be located. The meeting shall explain the exact proposed location of the equipment, outline relevant safety measures, and otherwise answer any questions the attendants might have. The applicant shall provide evidence of both the mailing and the meeting to the Commission.
- f. The following requirements shall be met for decommissioning:
1. A zoning permit issued which authorizes this use shall be subject to the condition that the owner shall comply with all applicable regulations of this Ordinance governing decommissioning.
  2. The facility owner and/or operator shall, at its expense, complete decommissioning of the wind energy system(s) within six (6) months after the end of the useful life of the facility or individual turbine(s) or, if applicable, within six (6) months after termination of any lease or agreement authorizing such use or the revocation by the City of Erie of a permit authorizing such use. A wind energy system will be presumed to be at the end of its useful life if no electricity is generated for a continuous period of twelve (12) months. The applicant shall be responsible for notifying the City of Erie's Zoning Officer, in writing, of the end of the useful life of the system or, if applicable, the termination of use of such systems.
  3. Decommissioning shall include removal of wind turbines, buildings, cabling, electrical components, fencing, roads, foundations to a depth of forty-eight inches and any other associated facilities.
  4. Disturbed earth shall be graded and re-seeded, unless the landowner requests in writing that the access roads or other land surface areas not be restored.
  5. Facility owner and/or operator shall provide evidence of financial assurance for decommissioning. Decommissioning Funds maybe in the form of a performance bond, surety bond, letter of credit, corporate guarantee or other form of financial assurance as may be acceptable to the City of Erie.

305.53 SMALL WIND ENERGY SYSTEMS (SWES) and COMMERCIAL/ INDUSTRIAL WIND ENERGY SYSTEMS (CIWES): A SWES may be permitted as a special exception in all zoning districts and a CIWES may be permitted as a special exception in all zoning districts, except R-1, R-1A and R-2, in accordance with the following regulations as approved by the Zoning Hearing Board of the City of Erie, or in Waterfront Zoning Districts by City Council.

- a. The maximum height of a SWES or CIWES shall be no taller than 160 feet in height.
- b. The minimum setback for a SWES or CIWES shall be 1.1 times the total height from the nearest occupied building, property line, or public or private street right of way.

NOTE: The total height shall include the height of any structure that a tower or pole is mounted on if it is not mounted directly at ground level. The setback distance shall be measured from the center of the wind turbine base to the nearest point on the foundation of the occupied building.

- c. All applicable performance standards set forth in Section 305.52 of the Zoning Ordinance governing Wind Energy Conversion Systems, as the same may be amended in the future, shall apply to and govern use of Small Wind Energy Systems or Commercial/Industrial Wind Energy Systems. Applicable performance standards include those set forth in Section 305.52c(1)-(12) generally- except changing the fence height of 305.52c(10) to six and half (6.5) feet for SWES - and others if relevant to a given application. Proof of homeowner's insurance covering the SWES or other applicable insurance covering the CIWES shall be supplied to the City of Erie prior to the issuance of a permit.
- d. In addition to the submission requirements of 305.52d(1)-(3), an applicant for a SWES or CIWES shall also hold a Neighborhood Informational Meeting with the same requirements as outlined in 305.52e. However, instead of appearing before the Planning Commission, the evidence of the meeting will be provided to the Zoning Hearing Board.
- e. The requirements for the decommissioning of a SWES and CIWES include those set forth in Section 305.52f(1)-(2). Decommissioning shall include removal of all turbines, towers, and poles.

**305.54 SOLAR COLLECTION SYSTEMS:** Solar Collection Systems shall be considered an accessory use in all Zoning Districts in accordance with the following requirements:

- a. Freestanding solar panels shall only be permitted in the rear and side yard.
- b. Freestanding solar panels located on the ground or attached to a framework located on the ground shall not exceed twenty (20) feet in height above the ground.

- c. Freestanding solar panels shall be set back as required for accessory uses in the districts in which they are located.
- d. The total coverage of a lot with freestanding solar panels cannot exceed the greater of 50% lot coverage or the maximum allowable coverage for the district in which they are located.
- e. Roof-mounted solar panels installed on a building or structure with a sloped roof shall not project vertically more than the height requirements for the district in which they are located.
- f. In addition to the requirements listed above, requirements for installation, structural certification, roof covering and so forth can be found in the "Solar Photovoltaic Installation Guideline" available in the Bureau of Code Enforcement. All panels must adhere to these guidelines.

**305.55 URBAN SOLAR FARM:** Urban Solar Farms shall be permitted in M-1, M-2, and 1-P Districts, and in W-M as a conditional use, in accordance with the following regulations:

- a. Solar farms shall be enclosed by perimeter fencing to restrict unauthorized access at a height of eight and a half (8.5) feet.
- b. The manufacturers' or installers' identification and appropriate warning signage shall be posted at the site in a clearly visible manner.
- c. On-site power lines shall, to the maximum extent practicable, be placed underground.
- d. Solar farms shall adhere to the setback, height, and coverage requirements of the district in which they are located.
- e. The following requirements shall be met for permit applications:
  - 1. A descriptive plot plan including setbacks, panel sizes, locations of property lines, buildings, and road right of ways.
  - 2. No urban solar farm shall be installed until evidence has been given to the City of Erie that the electric utility company has been informed of the customer's intent to install an interconnected customer-owned generator. Off-grid systems shall be exempt from this requirement.
  - 3. An affidavit or evidence of agreement between lot owner and the facility's owner or operator confirming that the owner or operator has permission of the property owner to apply for necessary permits for construction and operation of the urban solar farm.

4. Any other relevant studies, reports, certificates and approvals as may be reasonably requested by the City of Erie, including but not limited to design review.
- f. The following requirements shall be met for decommissioning:
1. Solar farms which have not been in active and continuous service for a period of one (1) year shall be removed at the owners or operators expense.
  2. The site shall be restored to as natural condition as possible within six (6) months of the removal.

**306 CONDITIONAL USES - WATERFRONT DISTRICTS:** A building permit or zoning certificate for a use in the Waterfront Districts, Sections 204.20, 204.21 and 204.22 will be issued by the Zoning Officer only after receiving the recommendations of the Design Review Committee, Planning Commission and City Council approval. The Design Review Committee shall only meet and review projects where there is a modification to the existing structure or a new structure is proposed. City Council shall hold a public hearing subject to public notice on all such proposed developments. The development shall demonstrate compliance with Section 306, as well as Section 305, if applicable, and all other appropriate sections of this Ordinance. Building permits for accessory uses, interior alterations, and minor additions/alterations (20% or less than the total square footage of the structure) are exempt from this process. However, any expansion of pre-existing uses onto other properties or outside existing leased and utilized land, whether minor in nature or not, shall be considered a new use and must be reviewed by the City Planning Commission as detailed above. However, any new development that is located on the water's edge and is required to provide "public access" as defined, will be a Conditional Use and must be voted on by the Erie City Council after City Planning Commission review and a Public Hearing, as the process for Conditional Uses is set forth in the Pennsylvania Municipalities Planning Code.

**306.10 Public Access - Waterfront Districts:** A free public access way\* must be regarded as an essential component of all developments in all Waterfront Districts. Every proposed site development that has access to the Bayfront water's edge shall show on the plans a proposed free public access way, abutting and parallel to the water's edge. The free public access way shall be of sufficient width to comfortably handle the expected amount of pedestrians, but shall not be less than twelve (12) feet in width. The construction of the free public access way shall be of such material as to be aesthetically pleasing and in harmony with the site development, and shall not consist of gravel, stone, grass or other unapproved material. When the free public access way is abutting the water's edge, and an apparent danger exists, a safety barrier shall be installed. It shall be the responsibility of the developer and/or property owner to construct and maintain the public access way. In addition, said developer or property owner shall assume all liability. The public access way shall be made accessible to the handicapped. The free public access way shall have north/south access to a City of Erie Public Right-of-Way at maximum intervals of seven hundred sixty (760) feet. The issuance of a building permit shall be contingent upon the developer providing a performance bond in an amount equal to one hundred ten (110%) percent of the cost of the proposed free public access way.

\*"Free Public Access way" - A constructed passage located within a Waterfront District designed for use by the general public for such activities as walking, jogging, fishing, etc., and made available for the public's use during daylight hours, and as mandated by City Council.

**306.20 Buildings or Structures - Waterfront Districts:** Buildings or structures which are part of a present or future group or complex shall have a unity of character and design. The relationship of forms and the use, texture, and color of materials shall be such as to create a harmonious whole. When the area involved forms an integral part of, is immediately adjacent to, or otherwise clearly affects the future of any established area, the design, scale, and location on the site shall enhance rather than detract from the character, value, and attractiveness of the surroundings.

**306.21** Buildings or structures located along strips of land or on single sites and not a part of a unified multi-building complex shall strive to achieve visual harmony with the surroundings. If they are built in undeveloped areas the three primary requirements shall be met - express honest design and construction; show proper design concepts; and be appropriate to the City of Erie.

**306.22** All facades visible to public or adjacent property shall be designed to create a harmonious whole.

**306.23** Harmony shall be achieved through the proper consideration of scale, proportions, site planning, landscaping, materials, and color.

**306.24** Exterior lighting may be used to illuminate a building and its grounds for safety purposes but in an aesthetic manner. Lighting is not to be used as a form of advertising in a manner that is not compatible to the neighborhood or in a manner that draws considerably more attention to the building or grounds at night than in the day. Lighting following the form of the building or part of the building will not be allowed if garish or detrimental to the environment. All fixtures used in exterior lighting are to be selected for functional and aesthetic value.

**306.25** Building surfaces, walls, and roofs shall not be garish.

**306.26** "Take-out" or "pick-up" windows of retail or wholesale establishments shall not be located on a building facade that faces a public right-of-way, unless they are designed in such a manner as to be an aesthetic asset to the building and neighborhood.

**306.27** All telephone, vending machines, or any facility dispensing merchandise or a service on private property shall be confined to a space built into the building or buildings or enclosed in a separate structure compatible with the main building.

**306.28** No advertising will be allowed on any exposed amenity or facility such as benches and trash containers.

**306.30 Marine Gasoline Stations - Waterfront Districts:** Marine gasoline stations, as accessory uses, must follow all criteria set forth herein.

**306.31** Symbolic color of the exterior facades or roofs may not be used unless they are harmonious with the atmosphere of the neighborhood and Erie.

**306.32** Exterior display or goods for sale or displays designating a service will not be allowed, except that a display of goods and tools of a service may be displayed on the pump island, and provided the goods and tools be such that they can be used or installed at the island.

**306.33** Areas used to store materials shall be screened from adjacent property and from the public view.

**306.40 Exterior Space - Waterfront Districts:** The scale of exterior space is to be relative to its neighborhood, adjacent properties, buildings, access (roads and pedestrian routes) and its activity. Building facades enclosing a space must be harmonious. Where, because of their use or age, like facades are not possible, consideration should be given to unifying the walls of the space by the application of landscaping or man-made objects of like design, at modular spacing. The floor of a space is of primary importance. Its materials, texture and color, contour and shadow on it are to be considered, not only in relation to space, but to its setting. Careful consideration shall be given to the preservation of natural vistas and to the future development of vistas which open into undeveloped areas. Of importance is the Bluff area. To the extent feasible, Bluff views shall be preserved.

**306.50 General Landscaping Criteria - Waterfront Districts:** Emphasis shall be placed upon landscaping as a means of achieving beauty in the community. It will be required on all projects, and in some projects and areas, it will be the primary tool available.

**306.51** Landscape design and planning shall be integrated with the overall area design concept and not be considered merely as an afterthought. Toward this end, proposed landscaping schemes will be evaluated as to their relationship to the existing natural landscape, developed and other proposed landscape, including those on adjacent properties and street rights-of-way and the building or buildings existing and proposed.

**306.52** The existing natural landscape character shall be preserved whenever possible. (As an example of this, in an area containing a stand of trees, the developer should preserve as many of these trees as possible and further landscape in a complementary manner, rather than destroy the existing trees and replant with a type of vegetation foreign to the immediate natural environment.)

Landscaping, includes not only trees and plantings, but paving, benches, fountains, exterior lighting fixtures, fences, and any other item of exterior furniture. All items of the landscape are to be selected not only for their functional value but for their aesthetic value, and must complement the whole.

**306.53** One of the uses of landscaping will be to screen. The achievement of this is left to the designer, whether by walls, fences, mounds of earth, or vegetation. It must be complementary to the whole as outlined above. Screening shall be employed as outlined in parking lots and to mask from the public view such service areas as trash and garbage areas, outside equipment of unaesthetic character, and accessory buildings or areas not enhancing or in keeping with the aesthetics of the project or neighborhood. Screening of air conditioning units and other mechanical equipment shall be accomplished in a manner that does not interfere with the proper operation and/or maintenance of such equipment.

**306.54** Landscaping shall be designed in such a manner as to impart its aesthetic character when viewed from any area accessible to the public or from adjacent properties. This is to include view from high-rises and bridges.

**306.55** All landscaping and plantings designated on the plans shall be installed in accordance with the specified height, spread and quality.

**306.56** Grass areas may be sodded, plugged or sprigged or seeded except that solid sod shall be used in swales or other areas subject to erosion. Seed, when used, shall be of a variety that will produce complete coverage within ninety (90) days from sowing. Where other than solid sod or grass seed is used, nurse grass seed shall be sown for immediate effect and protection until coverage is otherwise achieved.

**306.57** All elements of landscaping shall be installed so as to meet all other applicable ordinances and code requirements.

**306.58** Landscaped areas shall require protections from vehicular encroachment. Car stops shall be placed at least three (3) feet from the edge of such landscaped areas. Where a wheel stop or curb is utilized, the paved area between the curb/wheel stop and the end of the parking space may be omitted, provided it is landscaped in addition to the required landscaping provided. Car stops shall be located so as to prevent damage to any trees, fences, shrubs or landscaping by automobiles.

**306.59** Maintenance - The owner, occupant, tenant and the respective agent of each, if any, shall be jointly and severally responsible for the maintenance of all landscaping. Landscaping shall be maintained in a good condition so as to present a healthy, neat and orderly appearance at least equal to the original installation and shall be kept free from refuse and debris. Any dead vegetation and landscaping material shall be promptly replaced with healthy, living plantings. All landscaped areas shall be provided with an approved irrigation system or alternative.



**306.60 Parking Lots and Vehicular Use Areas - Waterfront Districts:** Parking lots and other vehicular use areas are to be designed as an aesthetic asset to a neighborhood and to the building, group of buildings, or facility they serve. A parking lot is to be considered an outside space, a transitional space which is experienced between the access (such as roads) and the building, group of buildings or other outside spaces which it serves. The parking lot, because it is viewed from above as well as eye level, should be designed accordingly.

**306.61** Parking lots, vehicular use areas, and their parked vehicles, if adjacent to a residential district, are to be effectively screened from the public view and from adjacent property and in a manner that is attractive and compatible with safety, the neighborhood, and facilities served.

**306.62** The atmosphere within the parking lot and vehicular use area is to be park-like rather than the harsh hardstand of paving. Trees are of primary importance in the landscape. They are not to be minimized in either height or quantity. The tree imparts, especially in a relatively flat area, a sense of three-dimensional space. It casts shadows that reduce the monotony of the expanse of paving and creates a refuge from the sun. Signs designating entrances, exits, and regulations are to be of a tasteful design. The pavement is to be more than wall to wall asphalt. It is recommended that pavement be varied in texture or color designating lanes for automobile traffic, pedestrian walks and parking spaces. Bright colored pavement is to be used only with restraint. In order to create a pleasant atmosphere, it is recommended that consideration be given to sculpture, fountains, gardens, pools and benches. Design emphasis is to be given to the entrances and exits to the lot. Trash, refuse and unaesthetic storage and mechanical equipment should be screened from the parking lot.

**306.63** Lighting is to be designed not only from the standpoint of safety and resistance to vandalism, but for visual effect. It should avoid any annoyance to the neighbors from brightness or glare. Low lights of a modest scale can be used along with feature lighting emphasizing plants, trees, barriers, entrances, exits. The fixtures are to be selected not only for their functional value but for their aesthetic qualities. They are to be considered furniture of the parking lot visible both day and night.

**306.64 Minimum Requirements for Off-Street Parking and Other Vehicular Use Areas:  
- Waterfront Districts:**

**306.64.1** All areas used for the display of parking of any and all types of vehicles, boats or heavy construction equipment, whether such vehicles, boats or equipment are self-propelled or not, and all land upon which vehicles traverse the property as a function of the primary use, hereinafter referred to as "other vehicular uses," including, but not limited to, activities of a drive-in nature such as filling stations, grocery and dairy stores, banks, restaurants, and the like, shall conform to the minimum landscaping requirements hereinafter provided.

**306.64.2** Ten percent (10%) minimum of the gross parking area is to be devoted to living landscaping, which includes grass, ground cover, plants, shrubs and trees. The gross parking area is to be measured from the edge of the parking and/or driveway paving and sidewalks, extended five (5) feet in all directions, but is not to include any area enclosed by the building or covered by a building overhand.

**306.64.3** Perimeter Screening: All parking lots and vehicular use areas shall be screened from all abutting properties and/or rights-of-way with a wall, fence, hedge or other durable landscape barrier. Any living barrier shall be established in a two (2) feet minimum wide planting strip. This living barrier shall be at least thirty (30) inches high at the time of planting and shall attain a minimum height of three (3) feet, one (1) year after planting. A non-living barrier shall be a minimum of three (3) feet high at the time of installation. In addition, one (1) tree in each forty (40) lineal feet or fraction thereof shall be provided in the perimeter landscape planting area. Trees referred to in this section shall be of a species common to Pennsylvania and having an average mature spread of crown of greater than fifteen (15) feet and having trunk(s) which can be maintained in a clean condition over five (5) feet of clear wood. Trees having an average mature spread of crown less than fifteen (15) feet may be substituted by grouping the same so as to create the equivalent of a fifteen (15) foot crown of spread. Trees species shall be a minimum of eight (8) feet overall height immediately after planting. Hedges, where installed, shall be planted and maintained so as to form a continuous, unbroken, solid, visual screen thirty-six (36) inches high with a maximum of one (1) year after time of planting. The remainder of the required landscaped areas shall be landscaped with grass, ground cover, or other approved landscape treatment excluding paving. All property other than the required landscape strip lying between the right-of-way and off-street parking area or other vehicular use area shall be landscaped with at least grass or other ground cover. This shall include the off-property swale between the actual pavement of a public street or alley and the right-of-way/property line.

Appropriate provisions of this section may be waived in the following situation:

Where a proposed parking area or other vehicular use area abuts an existing hedge, wall or other durable landscape barrier it may be used to satisfy the landscape barrier requirements of the subsection provided that said existing barrier meets all applicable standards of this Ordinance and protection against vehicular encroachment is provided for hedges.

**306.64.4 Interior Landscaping: - Waterfront Districts:** Interior areas of parking lots shall contain planter islands located so as to best relieve the expense of paving. A maximum of twelve (12) parking spaces in a row will be permitted without a planter island.

Interior areas of vehicular use areas shall contain planter islands located so as to best relieve the expense of pavement. This section may be modified under the following circumstances:

- a. When a strict application of this section will seriously limit the function of an area the required landscaping may be relocated with the approval of the Planning Commission.
- b. In an manufacturing project the Planning Commission may lower the overall landscape area from ten percent (10%) to five percent (5%) of the gross parking area. This reduction would apply only to the interior requirements. Perimeter minimums will not change.

**306.64.5** Planter islands shall be a minimum of fifty (50) square feet in area and shall contain at least one (1) tree having a minimum clear trunk of five (5) feet and a minimum overall height of eight (8) feet. The remainder shall be landscaped with shrubs, lawn ground cover or other approved material not to exceed three (3) feet.

**306.64.6** Existing Plant Material: In instances where health plant material exists on a site prior to its development, the above-mentioned standards may be adjusted to allow credit for such plant material. Such an adjustment is in keeping with and will preserve the intent of the Ordinance.

**306.70 Other Required Permits - Waterfront Districts:** Any proposed development located within the Waterfront Districts shall secure all necessary permits from various governmental agency's (U.S. Army Corps of Engineers, PA Department of Environmental Protection, Environmental Protection Agency, etc.) prior to conditional use approval.

A general Environmental Assessment of the entire Bayfront is to be done by the United States Corps of Army Engineers or the United States Environmental Protection Agency for the purpose of discovering problem areas on the Waterfront.

Each developer would assess his or her project for impacts on air, water and land to provide a general picture of the total development impact on the harbor, peninsula and the city shore, with all costs to be borne by each individual developer involved with the Bayfront development and that all reports shall be filed with City Council prior to final design plan approval as submitted to the City Planning Commission and City Council.

**307 SCREENING REQUIREMENTS:** Any commercial or manufacturing use which abuts a residential use or district shall provide screening as defined by this Ordinance. Those uses where five (5) or more cars will be parked on-lot shall provide the City with screening plan. That plan will clearly demonstrate how the use will effectively mitigate its effect on the neighboring property and on any street it abuts. For every new commercial or manufacturing development hereinafter established in the City of Erie, one tree is to be planted along all street frontages of the property for every 30 feet of frontage. Trees are to have a minimum 3” caliper. Trees may be planted either in the right-of-way or on private property along the street frontage at the property owner’s discretion.

**308 PLANNED RESIDENTIAL DEVELOPMENT:** Purpose: The purpose of the planned residential development regulations (PRD) is to encourage the flexibility in the design and development of land in order to promote its most appropriate use; to encourage grouping of housing and a mixture of housing types in alternative patterns and in a variety of ways; to facilitate the adequate and economical provision of streets and utilities; and to preserve the natural and scenic qualities of open areas. Planned residential developments are permitted in all Residential Districts in the City of Erie, with the exception of the Waterfront Residential District. The specific purposes of these districts in Erie City are:

R-1 and R-1A - In these Districts, the PRD is intended to facilitate the development of tracts of land for single family dwellings in areas where topography or economics have prevented previous development.

R-2 - In the R-2 District, the PRD is intended to facilitate the redevelopment of relatively small tracts of land while at the same time promoting better design.

R-3 - In the R-3 District, the PRD has a quite different purpose. Here the intent is to allow the development of tracts of land to promote good design and allowing a mixture of housing types and densities.

**308.1 Minimum Development Size:** In any district, no PRD may include less than 25,000 square feet of land.

**308.2 General Standards:** The planned residential development must meet all of the following general standards:

- a. The planned residential development is consistent with the Comprehensive Plan and this Ordinance's Statement of Community Development Objectives.
- b. The planned residential development is an effective and unified treatment of the development possibilities on the project site, and the development plan makes appropriate provision for the preservation of unique physical, cultural and historic resources.
- c. The planned residential development shall be planned and developed to harmonize with any existing or proposed development in the area surrounding the project site.
- d. Performance bond(s) for all public improvements in the development must be posted as required in the City of Erie Subdivision Ordinance.
- e. Connection to the City's sanitary sewer system shall be required.
- f. Connection to the City's public water supplies will be required.
- g. The height for buildings in any PRD shall meet the requirements set forth in Section 205 of this ordinance.

**308.3 Applicable Districts and Uses Permitted:** Planned residential developments may be approved in the R-2 and R-3 Residential Districts and may include the mixture of single-family, two-family and multi-family residential uses in a single development. In the R-1 and R-1A Residential Districts, PRD's may be approved for single family dwellings only.

**308.4 Calculations of Project Densities:** The number of dwelling units which may be constructed within the planned residential development shall be determined by dividing the gross project area by the required lot area per dwelling unit which is required in the respective zoning districts.

**308.5 Increase in Density** At the time the outline or preliminary development plan is filed, the applicant may apply for an increase in the densities permitted by the zone in which the planned residential development is to be approved by City Council, after conducting a public hearing pursuant to public notice, may authorize the developer to increase permitted densities by an amount up to ten percent (10%).

Additional increase in density may be granted by City Council up to twenty-seven percent (27%) providing:

- a. If common open space is developed to more intense usable open space providing facilities for active outdoor recreation, such as playgrounds, playground equipment, picnic facilities, ball fields and equipment, or other similar improvements to the open space, an additional ten percent (10%) increase in density may be permitted.

b. If item (a), above, is developed and unique indoor-outdoor buildings, to be used for recreation or other similar activities of the residents of the development, such as swimming pools, club houses, or other similar buildings are provided, then an additional seventeen percent (17%) increase in density may be permitted.

**308.6 Lot Size and Spacing of Buildings:** The location of all structures shall be as shown on final plans. The proposed location and arrangement shall not be detrimental to existing or prospective adjacent dwellings or to the existing or prospective development of the neighborhood. There shall be no minimum lot size, no minimum or maximum percentage of lot coverage and no minimum lot width in the planned residential development. However, every single-family dwelling shall have access to a public street, court, walkway, or other area dedicated to public use.

PRDs in the R-3 District are encouraged to mix housing types and densities. Generally, the design shall focus multi-family units in the center of the PRD with two-family and one-family units along the periphery.

Vehicular access to dwellings by means of adequate service drives and/or emergency entrances shall be provided in all cases where dwellings do not front on a public street, or where the City deems necessary for public safety. In general, the City will expect PRDs in the R-3 District to have at least two points of access to the existing City street system, if practical. Internal streets and sidewalks shall be constructed to City standards.

However, street cartway widths may be reduced from normal City requirements if adequate off-street parking is provided at a rate of 1.5 spaces per residential unit.

**308.7 Perimeter Requirements:** The requirements of this section apply only to structures located in an R-3 PRD within fifty (50) feet of the perimeter of a planned residential development. If the proposed PRD abuts single-family residences or an R-1 District, an adequate buffer area of thirty (30) feet will be required, at least ten (10) feet of which will be in screen planting. If topographical or other barriers do not provide adequate privacy for existing uses adjacent to the planned residential development, the Planning Commission may require either or both of the following:

- a. Structures located on the perimeter of the planned residential development must be set back by a distance sufficient to protect the privacy and amenity of adjacent existing uses, in no case less than the height of the buildings.
- b. Structures located on the perimeter of the planned residential development must provide a twenty (20) foot permanent planted screen in a manner which is sufficient to protect the privacy and amenity of adjacent existing uses.

**308.8 Common Open Space Required:** For all PRDs the development plan will contain area(s) to be allocated for common open space which satisfy the standards governing the usability and quality of common open space that is contained in this Ordinance.

No open area may be accepted as common open space under the provisions of this Ordinance unless it meets the following standards:

- a. The location, shape, size, and character of the common open space must be suitable for the planned residential development.
- b. Common open space must be suitably improved for its intended use with the exception of open space containing natural features worthy of preservation may be left unimproved. The building, structures, and improvements which are permitted in the common open space must be appropriate to the uses which are authorized for the common open space and must conserve and enhance the amenities of the common open space having regard to its topography and unimproved condition.
- c. The development schedule which is part of the development plan must coordinate the improvement of the common open space, the construction of buildings, structures, and improvements in the common open space, and the construction of residential dwellings in the planned residential development.
- d. If the final development plan provides for buildings, structures, and improvements in the common open space of a value in excess of ten thousand (\$10,000) dollars, the developer must provide a bond in the estimated amount of the improvements assuring that the buildings, structures, and improvements will be completed. The City Council shall release the bond or other assurance when the buildings, structures, or improvements have been completed according to the development plan.

**308.9 Conveyance and Maintenance of Common Space:** All land shown on the final development plan as common open space must be conveyed under one of the following options:

- a. It may be conveyed to a public agency which will agree to maintain the common open space and any buildings, structures, or improvements which have been placed on it, in which case the general public must have use of the open space.
- b. It may be conveyed to trustees provided in an indenture establishing an association or similar organization for the maintenance of the planned residential development. The common open space must be conveyed to the trustees subject to covenants to be approved by the City which restrict the common open space to the uses specified on the final development plan, and which provide for the maintenance of the common open space in a manner which assures its containing use for its intended purpose.

1. No common open space may be put to any use not specified in the final development plan unless the final development plan has been amended to permit that use.
2. If the common open space is not conveyed to a public agency, either one of the following methods of enforcement must be provided:
  - (a) The legal right to develop the common open space for the uses not specified in the final development plan must be approved by the City.
  - (b) The restrictions governing the use, improvement, and maintenance of the common open space must be stated as conditions to the conveyance of the common open space, the fee title to the common open space to vest in a public agency in the event of a substantial default in the stated conditions.
3. If the common open space is not conveyed to the City, or a public agency approved by the City, the covenants governing the use, improvement, and maintenance of the common open space shall then be enforceable by the City, and the instrument of conveyance shall so provide.
4. It is the purpose and intent of these regulations that the City shall have the authority and powers to require the adequate maintenance of common open space as set forth by Article VII of the Pennsylvania Municipalities Planning Code.

**308.10 Application for Tentative Approval of Planned Residential Development:** In order to provide an expeditious method for processing a development plan for a planned residential development under the provisions of this Ordinance, and to avoid the delay and uncertainty which would arise if it were necessary to secure approval, by a multiplicity of procedures, of a plat of subdivision as well as approval of a change in the zoning regulations otherwise applicable to the property, it is hereby declared to be in the public interest that all procedures with a planned residential development and the continuing administration thereof shall utilize the following provisions:

- a. An application for tentative approval of the development plan for a planned residential development shall be filed by or on behalf of the landowner.
- b. The application for tentative approval shall be filed by the landowner in such form, upon the payment of such a reasonable fee as is specified by the City. The application shall be filed with the Zoning Officer.
- c. All planning, zoning, and subdivision matters relating to the platting, use, and development of the planned residential development and subsequent modifications of the regulations relating thereto, to the extent such modification is vested in the City, shall be determined and established by the Planning Commission.



d. The provisions shall require only such information in the application as is reasonably necessary to disclose to the City of Erie:

(1) the location, size, and topography of the site and the nature of the landowner's interest in the land proposed to be developed;

(2) the density of land use to be allocated to parts of the site to be developed;

(3) the location and size of the common open space and the form of organization proposed to own and maintain the common open space (if required);

(4) the use and the approximate height, bulk, and location of buildings and other structures;

(5) the proposals for water supply and the disposition of sanitary waste and storm water;

(6) the substance of covenants, grants of easements, or other restrictions proposed to be imposed upon the use of the land, buildings, and structures including proposed easements or grants for public utilities;

(7) the provisions for parking of vehicles and the location and, if appropriate, width of proposed streets and public ways;

(8) the required modifications in the municipal land use regulations otherwise applicable to the subject property;

(9) the feasibility of proposals for energy conservation and the effective utilization of renewable energy sources; and

(10) in the case of development plans which call for development over a period of years, a schedule showing the proposed times within which applications for final approval of all sections of the planned residential development are intended to be filed and this schedule must be updated annually, on the anniversary of its approval, until the development is completed and accepted.

e. The application for tentative approval of a planned residential development shall include a written statement by the landowner setting forth the reasons why, in his opinion, a planned residential development would be in the public interest and would be consistent with the comprehensive plan for the development of the City.

f. The application for tentative approval shall be forwarded to the Planning Commission for their review and comments. The Planning Commission shall have thirty-five (35) days, from the date of filing, to complete their review.

g. All applications for tentative approval shall be forwarded to the Erie County Department of Planning for their study and recommendations in accordance with Section 704 of the Planning Code.

**308.11 Public Hearings:**

- a. Within sixty (60) days after the filing of an application for tentative approval of a planned residential development pursuant to this Ordinance, a public hearing pursuant to public notice of said application shall be held by the Planning Commission in the manner prescribed in the Pennsylvania Municipalities Planning Code. For PRD's that are accompanied by a request for an increase in density, the public hearing shall be held by City Council after receiving recommendations from the Planning Commission.
  
- b. The Planning Commission or City Council may continue the hearing from time to time, and where applicable, may refer the matter back to the Planning Commission for additional review, provided, however, that in any event, the public hearing or hearings shall be concluded within sixty (60) days after the date of the first public hearing.

**308.12 The Findings:**

- a. The Planning Commission or City Council, within sixty (60) days following the conclusion of the public hearing provided for in this part, shall, by official written communication, to the landowner, either:
  - (1) grant tentative approval of the development plan as submitted;
  - (2) grant tentative approval subject to specified conditions not included in the development plan as submitted; or
  - (3) deny tentative approval to the development plan.

Failure to so act within said period shall be deemed to be a grant of tentative approval of the development plan as submitted. In the event, however, the tentative approval is granted subject to conditions, the landowner may, within thirty (30) days after receiving a copy of the official written communication of the City notify such City Council of his refusal to accept all said conditions, in which case, the City shall be deemed to have denied tentative approval of the development plan. In the event the landowner does not, within said period, notify the governing body of his refusal to accept all said conditions, tentative approval of the development plan, with all said conditions, shall stand as granted.

- b. The grant or denial of tentative approval by official written communication shall include not only conclusions but also findings of fact related to the specific proposal and set forth the reasons for the grant, with or without conditions, or for the denial, and said communication shall set forth with particularity in what respects the development plan would or would not

be in the public interest, including, but not limited to, findings of fact and conclusions on the following:

(1) In those respects in which the development plan is or is not consistent with the comprehensive plan for the development of the City of Erie;

(2) the extent to which the development plan departs from zoning and subdivision regulations otherwise applicable to the subject property, including, but not limited to, density, bulk, and use, and the reason why such departures are or are not deemed to be in the public interest;

(3) the purpose, location, and amount of the common open space in the planned residential development, the reliability of the proposals for maintenance and conservation of the common open space, and the adequacy or inadequacy of the amount and purpose of the common open space as related to the proposed density and type of residential development;

(4) the physical design of the development plan and the manner in which said design does or does not make adequate provision for public services, provide adequate control over vehicular traffic, and further the amenities of light and air, recreation, and visual enjoyment.

(5) the relationship, beneficial or adverse, of the proposed planned residential development to the neighborhood in which it is proposed to be established; and

(6) in the case of a development plan which proposes development over a period of years, the sufficiency of the terms and conditions intended to protect the interests of the public and of the residents of the planned residential development in the integrity of the development plan.

d. In the event a development plan is granted tentative approval, with or without conditions, the City may set forth in the official written communication the time within which an application for final approval of the development plan shall be filed or, in the case of a development plan which provides for development over a period of years, the periods of time within which applications for final approval of each part thereof shall be filed. Except upon the consent of the landowner, the time so established between grant of tentative approval and an application for final approval shall not be less than twelve (12) months and, in the case of developments over a period of years, the time between applications for final approval of each part of a plan shall be not less than twelve (12) months.

### **308.13 Status of Plan After Tentative Approval:**

a. The official written communication provided for in this part shall be certified by the City Clerk of the City of Erie and shall be filed in his office, and a certified copy shall be mailed

to the landowner. Where tentative approval has been granted, it shall be deemed an amendment to the zoning map, effective upon final approval, and shall be noted on the zoning map.

b. Tentative approval of a development plan shall not qualify a plat of the planned residential development for recording nor authorize development or the issuance of any building permits. A development plan which has been given tentative approval as submitted, or which has been given tentative approval with conditions which have been accepted by the landowner (and provided that the landowner has not defaulted nor violated any of the conditions of the tentative approval), shall not be modified or revoked nor otherwise impaired by action of the City pending an application or applications for final approval, without the consent of the landowner, provided an application or applications for final approval is filed or, in the case of development over a period of years, provided applications are filed, within the period of time specified in the official written communication granting tentative approval.

c. In the event that a development plan is given tentative approval and thereafter, but prior to final approval, the landowner shall elect to abandon said development plan and shall so notify the governing body in writing, or in the event the landowner shall fail to file application or applications for final approval within the required period of time or times, as the case may be, the tentative approval shall be deemed to be revoked and all that portion of the area included in the development plan for which final approval has not been given shall be subject to those local ordinances otherwise applicable thereto as they may be amended from time to time, and the same shall be noted on the zoning map and in the records of the City Clerk of the City of Erie.

#### **308.14 Application for Final Approval:**

a. An application for final approval may be for all the land included in a development plan or, to the extent set forth in the tentative approval, for a section thereof. Said application shall be made to the Zoning Officer of the City of Erie within one (1) year of the official written communication granting tentative approval. The application shall include any drawings, specifications, covenants, easements, performance bond, and such other requirements as may be specified by this Ordinance, as well as any conditions set forth in the official written communication at the time of tentative approval. A public hearing on an application for final approval of the development plan, or the part thereof, submitted for final approval, shall not be required provided the development plan, or the part thereof submitted for final approval is in compliance with the development plan theretofore given tentative approval and with any specified conditions attached thereto. The submission shall be reviewed by the Zoning Officer and the Planning Commission for compliance prior to being forwarded to the City Council. This review is to take place in thirty-five (35) days.

b. In the event the application for final approval has been filed, together with all drawings, specifications, and other documents in support thereof, and as required by the Ordinance and

the official written communication of tentative approval, by the City shall, within forty-five (45) days of such filing, grant such development plan final approval.

c. In the event the development plan as submitted contains variations from the development plan given tentative approval, the City may refuse to grant final approval and shall, within forty-five (45) days from the filing of the application for final approval, so advise the landowner in writing of said refusal, setting forth in said notice the reasons why one or more of said variations are not in the public interest. In the event of such refusal, the landowner may either:

- (1) re-file his application for final approval without the variations objected, or
- (2) file a written request with the approving body that it hold a public hearing on his application for final approval.

If the landowner wishes to take either such alternate action, he may do so at any time within which he shall be entitled to apply for final approval, or within thirty (30) additional days if the time for applying for final approval shall have already passed at the time when the landowner was advised that the development plan was not in substantial compliance. In the event the landowner shall fail to take either of these alternative actions within said time, he shall be deemed to have abandoned the development plan. Any such public hearing shall be held pursuant to public notice within thirty (30) days after request for the hearing is made by the landowner, and the hearing shall be conducted in the manner prescribed in this part for public hearings on applications for tentative approval. Within thirty (30) days after the conclusion of the hearing, the City Council shall by official written communication either grant final approval to the development plan or deny final approval. The grant or denial of final approval of the development plan shall, in cases arising under this section, be in the form and contain the findings required for an application for tentative approval set forth in this Ordinance.

d. A development plan, or any part thereof, which has been given final approval, shall be so certified without delay by the City and shall be filed of record forthwith in the Office of the Recorder of Deeds before any development shall take place in accordance therewith. Upon the filing of record of the development plan, the zoning and subdivision regulations otherwise applicable to the land included in such plan shall cease to apply thereto. Pending completion, in accordance with the time provisions stated in Section 508 of the Pennsylvania Municipalities Planning Code, of said planned residential development or of that part thereof, as the case may be, that has been finally approved, no modification of the provisions of said development plan, or part thereof, as finally approved, shall be made except with the consent of the landowner. Upon approval of a final plat, the developer shall record the plat in accordance with the provisions of Section 513(a) and post financial security in accordance with Section 509 of the Pennsylvania Municipalities Planning Code.

e. In the event that a development plan, or a section thereof, is given final approval and thereafter the landowner shall abandon such plan or the section thereof that has been finally approved, and shall so notify the City of Erie in writing; or, in the event the landowner shall fail to commence and carry out the planned residential development in accordance with the time provisions stated in Section 508 of the Pennsylvania Municipalities Planning Code after final approval has been granted, no development or further development shall take place on the property included in the development plan until after the said property is reclassified by enactment of any amendment to the City of Erie Zoning Ordinance in the manner prescribed for such amendments.

**308.15 Enforcement:** All enforcement procedures under this section shall be consistent with Section 712.2 of the Pennsylvania Municipalities Planning Code.

## ARTICLE 4 - ADMINISTRATION AND ENFORCEMENT

**401 ZONING OFFICER:** The Zoning Officer, who shall be appointed by the Mayor and approved by City Council shall:

**401.10** Administer and enforce the provisions of this Ordinance.

**401.11** Issue Zoning Certificates.

**401.12** Maintain a permanent file on all Zoning Certificates and applications as public records.

### **402 ZONING CERTIFICATES:**

**402.1** A Zoning Certificate shall be obtained:

**402.10** at the request of the property owner

**402.11** at the time of a change of a nonconforming use to another nonconforming use

**402.12** at the time of a creation of a nonconforming use

**402.13** change a nonconforming use to a conforming use.

**402.20** Applications for a Zoning Certificate shall be accompanied by a plot plan showing clearly and completely the location, dimensions and use of any structures involved and such other information as the Zoning Officer may require for administration of this Ordinance, together with a filing fee.

**402.30** All permits and certificates which are granted by the Zoning Officer, or those granted as Special Exceptions, on appeal to the Board or as Conditional Uses shall be exercised promptly. If the use and/or the work so authorized is not initiated within one (1) year from the date of permit or certificate, then such certificate or permit shall be null and void.

### **403 VIOLATIONS AND PENALTIES:**

ENFORCEMENT NOTICE: When it appears to the City and/or the Zoning Officer that a violation has occurred, the Zoning Officer shall send an enforcement notice. The enforcement notice shall be sent to the owner of record of the parcel on which the violation has occurred, to any person who has filed a written request to receive enforcement notices regarding the parcel, and to any other person requested in writing by the owner of record. The enforcement notice shall state the following:

- a. The name of the owner of record and any other person against whom the City intends to take action.
- b. The location of the property in violation.

- c. The specific violation with a description of the requirements which have not been met, citing in each instance the applicable provisions of the Ordinance.
- d. The date before which the steps for compliance must be commenced and the date before which the steps must be completed.
- e. That the recipient of the notice has the right to appeal to the Zoning Hearing Board within a prescribed period of time in accordance with procedures set forth in this Ordinance.
- f. That failure to comply with the notice within the time specified, unless extended by appeal to the Zoning Hearing Board, constitutes a violation, with possible sanctions clearly described.

**CAUSES OF ACTION:** In case any building, structure, landscaping or land is, or is proposed to be, erected, constructed, reconstructed, altered, converted, maintained or used in violation of this Ordinance, the City, the Zoning Officer of the City, or any aggrieved owner or tenant of real property who shows that his property or person will be substantially affected by the alleged violation, in addition to other remedies, may institute any appropriate action or proceeding to prevent, restrain, correct or abate such building, structure, landscaping or land, or to prevent, in or about such premises, any act, conduct, commercial or use constituting a violation. When any such action is instituted by a landowner or tenant, notice of that action shall be served upon the City at least thirty (30) days prior to the time the action is begun by serving a copy of the complaint on the City Council of the City of Erie. No such action may be maintained until such notice has been given.

**ENFORCEMENT REMEDIES:** Any person, partnership or corporation who or which has violated or permitted the violation of the provisions of this Zoning Ordinance shall, upon being found liable therefor in a civil enforcement proceeding commenced by the City, pay a judgment of not more than five hundred (\$500) dollars per day plus all court costs, including reasonable attorney fees incurred by the City as a result thereof. No judgment shall commence or be imposed, levied or payable until the date of the determination of a violation by the district justice. If the defendant neither pays nor timely appeals the judgment, the City may enforce the judgment pursuant to the applicable rules of civil procedure. Each day that a violation continues shall constitute a separate violation, unless the district justice determining that there has been a violation further determines that there was a good-faith basis for the person, partnership or corporation violating this Ordinance to have believed that there was no such violation, in which event there shall be deemed to have been only one such violation until the fifth day following the date of the determination of a violation continues shall constitute a separate violation by the district justice and thereafter each day that a violation continues shall constitute a separate violation. All judgments, costs and reasonable attorney fees collected for the violation of zoning ordinances shall be paid over to the City. Nothing contained in this section shall be construed or interpreted to grant any person or entity other than the City and its Zoning Officer the right to commence any action for enforcement pursuant to this Section.



**403.10 RIGHT OF ENTRY:** In order to carry out the purpose and provisions of this Ordinance, the Zoning Officer or his designated agent, upon showing proper identification of office, may enter, examine, survey and inspect any premises during normal hours of operation of the use of the property or at a time in which a violation has been reported to occur. The owner, operator or occupant of every premises shall give the Zoning Officer or his agent free access for the purpose of such inspection, examination and survey.

**404 METHOD OF APPEAL:** Any person or City official aggrieved or affected by any decision of the Zoning Officer may appeal to the Board within a reasonable time, as provided by the rules of the Board, by filing a notice of appeal specifying the ground thereof. Upon denial of the appeal, no person shall re-appeal to the Board unless significant changes have been made to the request for appeal for a period of one (1) year from the date of the Board's denial.

**405 AMENDMENTS:**

INITIATIVE: The City Council may introduce and/or consider amendments to this Ordinance and to the Zoning Map, as proposed by a member of the City Council, the Planning Commission, or by a petition of a person or persons residing or owning property within the City.

PETITIONS: The preferred method to request a zoning text or map change is the petition. Petitions for amendments shall be filed with the Zoning Officer; and the petitioners, upon such filing, shall pay an advertising deposit and a filing fee, in accordance with a fee schedule affixed by City Council resolution

REFERRAL: Any proposed amendment presented to the City Council without written findings and recommendations from the City of Erie Planning Commission and the Erie County Planning Commission, shall be referred to these agencies for their review and recommendations prior to the public hearing by the City Council. The City Council shall not hold a public hearing upon such amendments until required reviews and recommendations are received or the expiration of thirty (30) days from the date that such proposed amendments were submitted to the City and County Planning Commissions.

ACTION: Before acting upon a proposed amendment, the City Council shall, as required by law, hold a public hearing thereon. Public notice of such hearing is required and shall contain a brief summary of the proposed amendment and reference to the place where copies of the same be examined, shall be published in accordance with the provisions of the Pennsylvania Municipalities Planning Code. If the proposed amendment involves a change to the Zoning Map, notice of the public hearing shall be posted at the affected tract in accordance with Section 609 of the Planning Code at least one (1) week prior to the date of the hearing.

CURATIVE AMENDMENTS: A landowner who desires to challenge on substantive grounds the validity of this Zoning Ordinance or Map or any provision thereof, which prohibits or restricts the use or development of land in which he has an interest, may submit a Curative Amendment to the City Council with a written request that his challenge and proposed amendment be heard and

decided as provided in Section 916.1 of the Pennsylvania Municipalities Planning Code (Act 247), as amended. The City Council shall commence a hearing thereon within sixty (60) days. As with other proposed amendments, the Curative Amendment shall be referred to the City of Erie Planning Commission and the Erie County Planning Commission at least thirty (30) days before the hearing is conducted by the City Council. Public notice shall be given in accordance with applicable provision of the Planning Code. The hearings shall be conducted in accordance with instructions as set forth by Section 916.1 of the Planning Code. The findings, actions and considerations of the City Council shall be in accordance with Section 609.1 of the Planning Code.

The City may institute a Municipal Curative Amendment in accordance with Section 609.2 of the Planning Code.

**405.10** City Council may, from time to time, on its own initiative or on petition signed by a majority of the property owners according to frontage in any district or portion thereof as large as one city block between two intersecting streets, amend, supplement or change the regulations, restrictions or district boundaries herein established or subsequently established.

All requests on the initiative of City Council for rezoning matters shall be accompanied by a letter by the person and/or persons requesting said rezoning, which letter shall state the purpose and intent of said person and/or persons for requesting the rezoning and include the desire of the request for the rezoning within the content of said letter. (82-1975).

The Petitioner for an amendment to said ordinance shall be required to affix to said petition, prior to the execution thereof by the owner's property affected by said amendment, a written statement as to the specific use to which said property will be put if the rezoning is granted. (75-1970)

The City Planning Commission shall forward by mail to all owners within a 500 foot radius of the area in which an amendment is proposed, a notice informing them of the time, place and date of any scheduled Public Hearing relative to new zoning changes and/or classifications being requested in their area; the term owners of property affected by said amendment being defined in Section 405.10 of Official Ordinance No. 64-2000.

**405.11** After the introduction of any petition or ordinance proposing amendment, supplement or change in the Zoning Ordinance, City Council shall refer such petition or ordinance within fifteen (15) days to the City Planning Commission for review. A report on said review, together with any recommendations, shall be given to City Council in writing, within 30 days from the date of said referral. If the Planning Commission shall fail to file such report, within the specific time and manner, it shall be conclusively presumed that the Planning Commission has approved the proposed amendment, supplement or change. Thereupon, Council shall fix a time for a public hearing and notice shall be given not more than thirty (30) days and not less than fourteen (14) days in advance of any public hearing required by this Act. Such notice shall be published in a newspaper of general circulation in the municipality. Such notice shall state the time and place of the hearing and the particular

nature of the matter to be considered at the hearing, including either the full text thereof, or a brief summary setting forth the principal provisions in reasonable detail and a reference place within the municipality where copies of the proposed ordinance or amendment may be examined. The public Hearing may not be held until at least 30 days after it is submitted to the Planning Commission. (1-1970)

No individual shall be permitted to remove or add his or her name to a rezoning petition after it is formally submitted to City Council. (11-1977)

**405.12** Petitions by the property owner for an amendment shall be filed with the City Clerk and the petitioner, upon such filing, shall pay a fee of as set by resolution of City Council which shall be deposited in the General Fund. Proposed amendments upon initiative of the Council of the City of Erie at the request of the property owner shall also be accompanied by a filing fee as set by resolution of City Council to be paid by said owner, which shall be deposited in the General Fund. Each parcel shall be considered as a separate request unless there is a common ownership of each parcel requested to be rezoned and the parcels abut. For the purposes of this Section, ownership may be by fee simple interest or pursuant to duly executed Articles of Agreement. (88-1977)(6-1979)(25-1985)(97-1989).

If after public hearing City Council rejects a petition for changing zone district boundaries for any lot, combination of lot, or portion of a lot, no person shall file a petition for changing the zone district boundaries for any lot, combination of lots, or portion of lots, including any lot, or portion of lots or any parts thereof which was rejected by Council for at least one (1) year from the date of Council's rejection.

**405.13** If after public hearing City Council rejects a request, either on Council's own initiative or by petition, to rezone a parcel of land, an affirmative vote of seven (7) members of City Council shall be required to consider a request on Council's own initiative to rezone that same parcel of land or any part thereof, if said request on Council's own initiative comes within one (1) year from the date of said request. (9-1978)

**406 Procedure to Obtain Preliminary Opinion:** In order not to unreasonable delay the time when a landowner may secure assurance that the ordinance or map under which he proposed to build is free from challenge, and recognizing that the procedure for preliminary approval of is development may be too cumbersome or may be unavailable, the landowner may advance the date from which time for any challenge to the ordinance or map will run as stated above, by the following procedure:

**406.1** The landowner may submit plans and other materials describing his proposed use or development to the Zoning Officer for a preliminary opinion as to their compliance with the applicable ordinances and maps. Such plans and other materials shall not be required to meet the standards prescribed for preliminary, tentative or final approval or for the issuance of a building permit so long as they provide reasonable notice of the proposed use or development and a sufficient basis for a preliminary opinion as to its compliance.

**406.2** If the Zoning Officer's preliminary opinion is that the use or development complies with the Zoning Ordinance and map, notice thereof shall be published, at the expense of the developer, once a week for two successive weeks in a newspaper of general circulation in the municipality. Such notice shall include a general description of the proposed use or development and its location, by some readily identifiable directive, and the place and times where the plans and other materials may be examined by the public. The favorable preliminary approval, as stated above, and the time therein specified for commencing a proceeding with the board shall run from the time when the second notice thereof has been published. The zoning officer shall also forward a copy of the preliminary approval to all adjoining property owners of the approved project.

## ARTICLE 5 - ZONING HEARING BOARD

**501 CREATION:** There is hereby created a Zoning Hearing Board, herein referred to as the “Board,” consisting of five (5) members, who are residents of the City appointed by the City Council pursuant to the Pennsylvania Municipalities Planning Code, as amended. Said Board shall perform all the duties, and exercise all powers prescribed by said Code and as herein further provided.

**502 APPOINTMENT:** The terms of office of the Board shall be five years and shall be so fixed that the term of office of one (1) member shall expire each year. The Board shall promptly notify the City Council of any vacancies which occur. Appointments to fill vacancies shall be only for the unexpired portion of the term. Members of the Board shall hold no other office in the City, nor be a member of the Planning Commission.

**503 REMOVAL OF MEMBERS:** Any Board member may be removed for malfeasance, misfeasance or nonfeasance in office, or for other just cause, by a majority vote of the City Council, taken after the member has received fifteen (15) days advance notice of the intent to take such a vote. A hearing shall be held in connection with the vote if the member shall request it in writing.

**504 ORGANIZATION OF BOARD:** The Board shall elect from its own membership its officers, who shall serve annual terms as such and may succeed themselves. For the conduct of any hearing or the taking of any action, a quorum shall be not less than the majority of all the members of the Board. The Board may appoint a hearing officer from its own membership to conduct any hearing on its behalf, and the parties may waive further action by the Board as provided in Section 908 of the Planning Code. The Board may make, alter and rescind rules and forms for its procedure, consistent with City ordinances and laws of the Commonwealth. The Board shall keep full public records of its business and shall submit a report of its activities to the City Council annually.

**505 EXPENDITURES FOR SERVICES:** Within the limits of funds appropriated by the City Council, the Board may employ or contract for secretaries, clerks, legal counsel, consultants and other technical and clerical services. Members of the Board may receive compensation for the performance of their duties, as may be fixed from time to time by the City Council, but in no case shall it exceed the rate of compensation authorized to be paid to the members of the City Council.

**506 LEGAL COUNSEL:** Where legal counsel is desired, an attorney, other than the City Solicitor, shall be used.

**507 HEARINGS:** The Board shall conduct hearings and make decisions in accordance with the following requirements. (NOTE: The following requirements are taken from the Pennsylvania Municipalities Code (Act 247 of 1968 as amended) any subsequent revisions to this code are adopted by this reference.

1. Public notice shall be given and written notice shall be given to the applicant, the zoning officer, such other persons as the governing body shall designate by ordinance and to any person who has made timely request for the same. Written notices shall be given at such

time and in such manner as shall be prescribed by ordinance or, in the absence of ordinance provision, by rules of the board. In addition to the written notice provided herein, written notice of said hearing shall be conspicuously posted on the affected tract of land at least one week prior to the hearing.

2. The City Council may prescribe reasonable fees with respect to hearings before the Zoning Hearing Board. Fees for said hearings may include compensation for the secretary and members of the zoning hearing board, notice and advertising costs and necessary administrative overhead connected with the hearing. The costs, however, shall not include legal expenses of the Zoning Hearing Board, expenses for engineering, architectural or other technical consultants or expert witness costs.

3. The hearing shall be held within sixty (60) days from the date of the applicant's request, unless the applicant has agreed in writing to an extension of time.

4. The hearings shall be conducted by the Board or the Board may appoint any member as a hearing officer. The decision, or, where no decision is called for, the findings shall be made by the Board, but the parties may waive decision or findings by the Board and accept the decision or findings of the hearing officer as final.

5. The parties to the hearing shall be the City, any person affected by the application who has made timely appearance of record before the Board, and any other person including civic or community organizations permitted to appear by the Board. The Board shall have power to require that all persons who wish to be considered parties enter appearances in writing on forms provided by the Board for that purpose.

6. The chairman or acting chairman of the Board or the hearing officer presiding shall have power to administer oaths and issue subpoenas to compel the attendance of witnesses and the production of relevant documents and papers, including witnesses and documents requested by the parties.

7. The parties shall have the right to be represented by counsel and shall be afforded the opportunity to respond and present evidence and argument and cross-examine adverse witnesses on all relevant issues.

8. Formal rules of evidence shall not apply, but irrelevant, immaterial, or unduly repetitious evidence may be excluded.

9. The Board or the hearing officer, as the case may be, shall keep a stenographic record of the proceedings. The cost of the original transcript shall be paid by the Board if the transcript is ordered by the Board or hearing officer or shall be paid by the person appealing from the decision of the Board if such appeal is made, and in either event the cost of additional copies shall be paid by the person requesting such copy or copies. In other cases the party requesting the original transcript shall bear the cost thereof.

10. The Board or the hearing officer shall not communicate, directly or indirectly, with any party or his representatives in connection with any issue involved except upon notice and opportunity for all parties to participate, except that advice from the Board's Solicitor is exempt from this restriction; shall not take notice of any communication, reports, staff memoranda, or other materials unless the parties are afforded an opportunity to contest the material so noticed; and shall not inspect the site or its surroundings after the commencement of hearings with any party or his representative unless all parties are given an opportunity to be present.

11. The Board or the hearing officer, as the case may be, shall render a written decision or, when no decision is called for, make written findings on the application within forty-five (45) days after the last hearing before the Board or hearing officer. Where application is contested or denied, each decision shall be accompanied by findings of fact and conclusions based thereon together with the reasons therefor. Conclusions based on any provisions of this Ordinance or the Planning Code, or any rule or regulation shall contain a reference to the provision relied on and the reasons why the conclusion is deemed appropriate in the light of the facts found. If the hearing is conducted by a hearing officer, and there has been no stipulation that his decision or findings are final, the Board shall make his report and recommendations available to the parties within forty-five (45) days, and the parties shall be entitled to make written representations thereon to the Board prior to final decision or entry of findings, and the Board's decision shall be entered no later than thirty (30) days after the report of the hearing officer. Where the Board fails to render the decision within the period required by this Ordinance or the Planning Code, or fails to hold the required hearing within sixty (60) days from the date of the applicant's request for a hearing, the decision shall be deemed to have been rendered in favor of the applicant unless the applicant has agreed in writing or on the record to an extension of time. When a decision has been rendered in favor of the applicant because of the failure of the Board to meet or render a decision as herein above provided, the Board shall give public notice of said decision within ten (10) days in the same manner as provided in the Pennsylvania Municipalities Planning Code. Nothing in this subsection shall prejudice the right of any party to appeal the decision to a court of competent jurisdiction.

12. A copy of the final decision or, where no decision is called for, of the findings shall be delivered to the applicant personally or mailed to him not later than the day following its date. To all other persons who have filed their name and address with the board not later than the last day of the hearing, the board shall provide by mail or otherwise, brief notice of the decision or findings and a statement of the place at which the full decision or findings may be examined.

**508 BOARD'S FUNCTIONS:**

1. Substantive challenges to the validity of any land use ordinance, except those brought before the governing body pursuant to Sections 609.1 and 916.1(a)(2) of the Planning Code.
2. Challenges to the validity of a land use ordinance raising procedural questions or alleged defects in the process of enactment or adoption which challenges shall be raised by an appeal taken within thirty (30) days after the effective date of said ordinance. Where the ordinance appealed from is the initial zoning ordinance of the City and a zoning hearing board has not been previously established, the appeal raising procedural questions shall be taken directly to court.
3. Appeals from the determination of the Zoning Officer, including, but not limited to, the granting or denial of any permit, or failure to act on the application therefor, the issuance of any cease and desist order or the registration or refusal to register any nonconforming use, structure or lot.
4. Appeals from a determination by the City Engineer or the Zoning Officer with reference to the administration of any floodplain or flood hazard ordinance or such provisions within a land use ordinance.
5. Applications for variances from the terms of the zoning ordinance and flood hazard ordinance or such provisions within a land use ordinance, pursuant to Section 910.2 of the Planning Code and Section 608(9) of this Ordinance.
6. Applications for Special Exceptions under this Ordinance or the Flood Plain Ordinance. See also 608(10).
7. Appeals from the Zoning Officer's determination under Section 916.2 of the Planning Code.
8. Appeals from the determination of the Zoning Officer or City Engineer in the administration of any land use ordinance or provision thereof with reference to sedimentation and erosion control and storm water management insofar as the same relate to development not involving Article V or VII applications of the Planning Code.
9. Variances: The Board shall hear requests for variances where it is alleged that the provisions of this Ordinance inflict unnecessary hardship upon the applicant. The Board may by rule prescribe the form of application and may require preliminary application to the Zoning Officer. The Board may grant a variance provided that following findings are made where relevant in a given case:
  - a. That there are unique physical circumstances or conditions, including irregularity, narrowness, or shallowness of lot size or shape, or exceptional topographical or other



physical conditions peculiar to the particular property, and that the unnecessary hardship is due to such conditions, and not the circumstances or conditions generally created by the provisions of this Ordinance in the neighborhood or district in which the property is located;

b. That because of such physical circumstances or conditions, there is no possibility that the property can be developed in strict conformity with the provisions of this Ordinance and that the authorization of a variance is therefor necessary to enable the reasonable use of the property;

c. That such unnecessary hardship has not been created by the applicant;

d. That the variance, if authorized, will not alter the essential character of the neighborhood or district in which the property is located, nor substantially or permanently impair the appropriate use or development of adjacent property, nor be detrimental to the public welfare; and

e. That the variance, if authorized, will represent the minimum variance that will afford relief and will represent the least modification possible of the regulation in issue.

f. Such modifications are necessary to provide “reasonable accommodation” required by the American with Disabilities Act and/or the Federal Fair Housing Act and/or applicable State law, as amended.

g. Only persons who the applicant proves have “disabilities” as defined in and protected by such laws are served.

h. The standards for such accommodation as listed above are met.

In granting any variance, the Board may attach such reasonable conditions and safeguards as it may deem necessary to implement the purpose of this Ordinance.

10. Special Exceptions: The Board shall hear and decide requests for such Special Exceptions in accordance with the standards and criteria of this Ordinance. In granting a Special Exception, the Board may attach such reasonable conditions and safeguards, in addition to those expressed in this Ordinance, as it may deem necessary to implement the purposes of the Planning Code and the Zoning Ordinance.

**509 PARTIES APPELLANT BEFORE BOARD:** Appeals under Section 608 and proceedings to challenge the Ordinance under Section 608 may be filed with the Board, in writing, by the landowner affected, any officer or agency of the City, or any person aggrieved. Requests for a variance under Section 608 may be filed with the Board by any landowner or any tenant with the permission of such landowner.

**510 TIME LIMITATIONS; PERSONS AGGRIEVED:** No person shall be allowed to file any proceeding with the Board later than thirty (30) days after an application for development, preliminary or final, has been approved by an appropriate City officer, agency or body if such proceeding is designed to secure reversal or to limit the approval in any manner unless such person alleges and proves that he had no notice, knowledge, or reason to believe that such approval had been given. If such person has succeeded to his interest after such approval, he shall be bound by the knowledge of his predecessor in interest. See also Section 914.1 of the Planning Code.

A building permit or zoning certificate must be issued within one year from the date of the Zoning Hearing Board written decision or any appellate proceedings which may follow. Failure to do so will result in a voided decision.

**511 STAY OF PROCEEDINGS:** Upon filing of any proceeding referred to in Section 913.3 of the Pennsylvania Municipalities Planning Code and during its pendency before the Board, all land development pursuant to any challenged ordinance, order or approval of the Zoning Officer or of any agency or body, and all official action thereunder shall be stayed unless the Zoning Officer or any other appropriate agency or body certifies to the Board facts indicating that such stay would cause imminent peril to life or property, in which case the development or official action shall not be stayed otherwise than by a restraining order, which may be granted by the Board or by the court having jurisdiction of zoning appeals on petition after notice to the Zoning Officer or other appropriate agency or body. See also Section 915.1 of the Planning Code.

## ARTICLE 6 - DEFINITIONS

For the purpose of this Ordinance certain terms and words are hereby defined. Words used in the present tense shall include the future, the singular number shall include the plural and the plural number shall include the singular; the word "shall" is mandatory, the word "may" is permissive; the word "person" includes a firm, association, organization, partnership, trust, company or corporation as well as an individual; the words "used or "occupied" include the words intended, designed, or arranged to be used or occupied.

**ABANDON-ABANDONMENT:** For the purpose of this Ordinance, this term is being defined only for the purpose of dealing with the nonconforming use of structures. To make a determination of abandonment, the Zoning Officer shall assume that any use which has not been operational for a period of two years has been voluntarily abandoned by the owner.

**ABUT** To have a common boundary or being along contiguous lot lines that are not separated by a street or alley.

**ACCESSORY BUILDING:** A subordinate building, the use of which is customarily incidental to that of the principal building on the same lot.

**ACCESSORY USE:** A use which is subordinate to and customarily associated with the principal use of a lot or a building and located on the same lot provided that it is not noxious or offensive to neighboring permitted uses by the reason of appearance or emission of odor, dust, smoke, gas, vibration or noise.

**ADJACENT** Being along lot lines that are contiguous or that are only separated by a street or alley.

**ADULT BOOK STORE:** An enclosed building with floor plans which conform to the requirements of 68 Pa. C.S.A. 5501 et seq. providing books, reading material, literature or other objects representing material distinguished or characterized by an emphasis on matter depicting, describing or relating to "Specified Sexual Activities" or "Specified Anatomical Areas" for distribution, purchase, observation or review by patrons therein.

**ADULT DAY CARE** A facility in which adult daily living services are simultaneously provided for four (4) or more clients who are not relatives of the operator for part of a 24 hour day. Client, in this definition, is a person 16 years of age or older who

required assistance to meet personal needs and perform activities of daily living.

**ADULT LIVE ENTERTAINMENT:**

A live performance, display, or dance of any type which has a significant or substantial part of the performance any actual or simulated performance of specified activities, as defined in the Zoning Ordinance, or exhibition or viewing of specified anatomical areas, as defined in the Zoning Ordinance, removal of articles of clothing or appearing unclothed, pantomiming, modeling or any other personal services offered customers. This definition does not included any establishments not within the scope of the state regulation of adult-oriented establishments as set forth at 68 Pa. C.S.A. 5501 et. seq.

**ADULT MINI-MOTION PICTURE THEATER**

An enclosed building with floor plans which conform to the requirements of 68 Pa. C.S.A. 5501 et seq. with a capacity for less than fifty (50) persons used for presenting material distinguished or characterized by an emphasis on matter depicting, describing or relating to "Specified Sexual Activities" or "Specified Anatomical Areas" (as defined herein for observation by patrons therein).

**ADULT MOTION PICTURE THEATER:**

An enclosed building with floor plans which conform to the requirements of 68 Pa. C.S.A. 5501 et seq. with a capacity of fifty (50) or more persons used for presenting material distinguished or characterized by an emphasis on matter depicting, describing, or relating to "Specific Sexual Activities" or "Specified Anatomical Areas" (as defined herein for observation by patrons therein).

**ALLEY:**

A public way open to public travel which affords generally a secondary means of vehicular access to abutting lots and is not intended for general traffic circulation.

**ALTER OR ALTERATION:**

A change in the appearance of a building, structure, site, or object which is not otherwise covered by the definition of demolition, or any other change for which a permit is required, or for which a Certificate of Appropriateness may be required from the City Council. Alteration includes, but is not limited to, additions of, or changes in, the materials,

shape, or design of any kind of exterior cladding; window replacement; re-roofing; cleaning by chemical means, sandblasting, or high-pressure water wash or pointing of a building, structure, or object; or any change in the supporting members of a building, structure, or object, such as bearing walls, roof rafters, floor joists, or stairways, which might impair or ruin the structural integrity.

ANIMAL CARE:	The boarding, breeding, housing, keeping, or medical treatment of five (5) or more animals six (6) months old or older.
APARTMENT	See “Multi –Family” under “Dwellings”
AUTO REPAIR SHOP	A facility which makes mechanical repairs to motor vehicles. Included but not limited to engine or transmission repairs, and other minor maintenance items, but not used for the dismantling or scrapping of motor vehicles. An Auto Repair Shop may also include Auto Sales of not more than four (4) vehicles, conditioned upon the fact that all Off Street Parking requirements are met. (
AUTO SALES	A facility involving the sale or rental of operable motor vehicles, boats, trailers, recreational vehicles, boat trailers, trucks, construction vehicles or similar equipment. Auto repair may occur as an accessory use
AUTOMOBILE WRECKING	see “Scrap yard”
BALCONY:	An above-grade platform that projects from the wall of a building and is enclosed by a parapet or railing and is used for more than ingress/egress which may or may not be covered.
BASEMENT:	A portion of a building located partly underground, but having less than half of its clear floor-to-ceiling height below the average grade of the adjoining ground.
BED AND BREAKFAST INN	A building involving the rental of overnight sleeping accommodations for temporary visitors to the area, provides meals for overnight guests only and which does not routinely involve the rental of accommodations for periods of more than 14 days.

BETTING USE	A use where lawful gambling activities are conducted.
BOARD:	The Zoning Hearing Board of the City of Erie.
BOTTLE CLUB:	A place of assembly owned, maintained or leased, for pecuniary gain, in which no intoxicating liquors are sold, but where patrons are permitted to bring intoxicating liquors upon the premises for their own use and consumption. The floor plan for a place of assembly shall conform to the requirements of 68 Pa. C.S.A. 5501 et seq.
BUILDING:	Any structure designed or intended for the support, enclosure, shelter or protection of persons, animals or property.
CAR WASH	A building or portion thereof where automobiles are cleaned mechanically, using a conveyor, sprayer, blower, steam-cleaning equipment or other device.
CELLAR:	A portion of a building located partly or wholly underground and having half or more than half of its clear floor-to-ceiling height below the average grade of the adjoining ground.
CHILD CARE	Care given to children under the age of 16 for a given part of a 24 hour day, on a regular basis. Child care does not include care furnished in churches during religious services, schools or care given by relatives. Child Care is further defined below:  <b>DAY CARE CENTER:</b> An establishment licensed by the Commonwealth of Pennsylvania, which provides supervised care for seven (7) or more children, who are not residents of the premises.  <b>FAMILY DAY CARE HOME:</b> Any premises other than the child's own home, operated for profit, or not for profit, in which child day care is provided at any time to four, five or six (4, 5, or 6) children who are not relatives of the care giver as defined and regulated by the Commonwealth of Pennsylvania.  <b>HOME CHILD CARE:</b> Within a dwelling unit, the conduct of providing supervised care of not more than three (3) children who are not residents of the unit.

CLEAR SIGHT TRIANGLE	A triangular area of unobstructed vision on corner lots formed by a fifteen foot (15) distance along either property line which fronts along a street.
COMMERCIAL DISTRICT	C-1, C-2, C-3, C-4 Zoning Districts
COMMERCIAL RECREATION:	A commercial or institutional facility which offers various recreational opportunities for its patrons, including but not limited to such activities as dance halls, indoor concerts, psychic readings, computer use, golf course, bowling, ice skating, swimming pools, video and various games. (8/07)
COMMERCIAL SERVICE:	Any commercial activity which renders service to other commercial or manufacturing enterprises.
COMMERICAL/INDUSTRIAL SCALE WIND ENERGY SYSTEMS:	A wind energy conversion system consisting of one or more more wind turbines, towers, and associated controls and conversion electronics which has a rated capacity of greater than one hundred (1 00) kilowatts (kW) and which is designed and used solely to generate power to offset utility costs.
COMMUNICATIONS ANTENNA:	Any device used for the transmission or reception of radio, television, wireless telephone, pager, commercial mobile radio service or any other wireless communications signals, including without limitation omni-directional or whip antennas and directional or panel antennas, owned or operated by any person or entity licensed by the Federal Communications Commission (FCC) to operate such device. This definition shall not include private residence mounted satellite dishes or television antennas or amateur radio equipment including without limitation ham or citizen band radio antennas.
COMMUNICATIONS EQUIPMENT BUILDING:	An unmanned building or cabinet containing communications equipment required for the operation of communications antennas and covering an area on the ground not greater than two hundred fifty (250) square feet.

COMMUNICATIONS TOWER:	A structure other than a building, such as a monopole, self-supporting or guyed tower, designed and used to support communications antennas.
COMMUNITY GARAGE	A group of at least three (3) private garages, detached or under one roof and contained on a single lot, arranged in a row or around a common means of access, only for the residents within 500 feet of the proposed garage. A minimum of one of the three garage areas must be rented to an individual meeting the qualifications above. The garages shall be used for the storage of an automobile. Other personal items may also be stored.
COMPUTER USERS CENTER	The commercial use of a structure for access to a computer, the internet or other text messaging systems.
CONDITIONAL USE	A use which by virtue of its own peculiar characteristics may be permitted in certain areas only after review and approval by City Council.
COPY SHOP:	A commercial which copies papers and documents for individuals and commercial using electronic photocopy devices, including ancillary services such as collation, stapling and binding. However, the term does not include commercial printing operations, where heavy presses and similar machines are required.
CORRECTIONAL FACILITY	A publicly or privately operated facility housing persons awaiting trial or persons serving a sentence after being found guilty of a criminal offence. A Limited Correctional Facility shall have less than 50 beds, a General Correctional facility shall contain 50 or more beds.
COUNCIL:	The City Council of the City of Erie, Erie County, Pennsylvania.
CUSTODIAL CARE FACILITY	A facility providing custodial care and treatment in a protective living environment for persons residing by court placement, including, but not limited to: pre/post-correctional facilities, juvenile detention facilities, and temporary detention facilities. This includes halfway houses and similar facilities for people on probation or parole who have been placed there as a condition of judicial order.



**DEMOLITION:**

In the context of this Ordinance, the dismantling or tearing down of all or part of any identified historic resource, or other building or structure located in a certified Historic Overlay District, and all operations incidental thereto.

**DESIGN REVIEW COMMITTEE:** A committee established to advise the Planning Commission on design concerns. This committee shall be comprised of:

- a. Registered architect (2 members)
- b. Landscape architect or a landscape contractor with at least five (5) years' experience (1 member)
- c. Representative of the Department of Economic and Community Development (1 member)
- d. Representative of the Erie County Historical Society (1 member)

This group is advisory only and shall be appointed by the Planning Commission. Terms of appointment shall be four (4) years.

**DETACHED ACCESSORY STRUCTURE**

A structure which is subordinate to and customarily associated with the principal use of a lot or a building. Such structure shall be located on the same lot as and a minimum of six feet from the principal structure.

**DORMITORY**

A building or portion thereof which contains living quarters for four or more students, staff or members of a college, university, primary or secondary boarding school, theological school, or other comparable organization, provided that such building is either owned or managed by such organization. This definition excludes single family and two-family dwellings. (8/09)

**DRIVE-IN COMMERCIAL:**

A place providing service to automobiles or the occupants thereof directly, usually without requiring the occupants to leave the automobile. Such service includes minor repairs, replacements or services to the automobile, serving food or drink to the occupants, or providing entertainment or facilities for transacting commercial without leaving the automobile.

Some drive-in businesses such as gasoline service stations are described separately. Further, the provision of an off-street parking lot for the convenience of customers served or doing commercial within a building or structure does not constitute a drive-in commercial.

**DWELLING:** Any building or portion thereof which is designed for or used for residential purposes. The word "Dwelling" shall not include hotels, motels, or other structures used for transient residence.

**DWELLING\ One-Family:** A building designed for or occupied by one (1) family only.

**DWELLING\ Two-Family:** A building designed for or occupied by two (2) families living independently of each other.

**DWELLING\ Multiple-Family:** A building or portion thereof, designed for or occupied by three (3) or more families living independently of each other.

**DWELLING UNIT** A room or group of rooms located within a building and forming a single habitable unit with facilities which are used or intended to be used for living, sleeping, cooking and eating, and which is occupied by a maximum of one "family" living together as a single common household.

**EATING AND DRINKING ESTABLISHMENT** Any establishment at which ready-to-eat food and beverages are sold, and at least a portion is consumed on the premises. A facility that primarily involves off-site delivery of ready-to-eat food shall also be considered a restaurant.

**ESSENTIAL SERVICE:** The erection, construction, alteration or maintenance by public utilities or municipal or other governmental agencies of underground or overhead gas, electrical, steam or water transmission or distribution systems, including poles, wires, mains, drains, sewers, pipes, conduit cables, fire alarm boxes, police call boxes, traffic signals, hydrants, street signs, and other similar equipment and accessories in connection therewith, reasonably necessary for the furnishing of adequate service by such public utilities or municipal or other governmental agencies or for the public health or safety or general welfare.

**EXTERIOR ALTERATION:** The alteration of exterior features which can be seen from a

public street or way.

**EXTERIOR FEATURES:**

The architectural style, design, and general arrangement of the exterior of a building, structure, or identified historic resource, including the color, nature, and texture of building materials, and the type of style of all windows, doors, light fixtures, signs, or other similar items found on or related to the exterior of a building, structure, or object; all those exterior elements normally exposed to the weather.

**FAMILY:**

A family is:

- a. A single person occupying a dwelling unit and maintaining a household, or
- b. Two (2) or more relatives, occupying a dwelling unit, living together and maintaining a common household, including not more than two (2) boarders or roomers.
- c. Not more than three (3) unrelated persons occupying a dwelling unit, living together and maintaining a common household.
- d. Permanent group homes for the handicapped or family-like living arrangements for handicapped persons. Groups of more than three (3) unrelated persons may be treated as a “family” if they are defined as “handicapped” under the Fair Housing Act Amendments to the Federal Civil Rights Act, and meet the criteria of a Group Home Special Exception. Please note: Handicapped persons shall be those who are so designated under the Fair Housing Amendment (1988) to the Federal Civil Rights Act of 1968.

**FENCE**

An artificially constructed barrier of wood, masonry, stone, wire, metal or other manufactured material or a combination of materials erected for the enclosure of areas.

**FITNESS CENTER**

The commercial use of a room or building equipped for exercise.

**FLOOR AREA:**

The sum of the gross horizontal areas of one or more floors of a building excluding cellar, attic, garage, open breezeway, open porches and terraces.

FRATERNITY HOUSE	Also Sorority house. A building designated or arranged for occupancy by an incorporated nonprofit organization of full-time students of an accredited college or university.
FREE PUBLIC ACCESS WAY:	A constructed passage abutting and parallel to the water's edge located within a Waterfront District designed for use by the general public for such activities as walking, jogging, fishing, etc., and made available for the public's use during daylight hours, and as mandated by City Council.
GARAGE, PRIVATE:	An accessory building or part of a principal building used only for the storage of private motor vehicles and other personal affects of the occupants of the principal structure. Such a garage shall not be used for commercial purposes, unless specifically approved for such purposed, nor shall any repairs be made to motor vehicles within the garage other than to those vehicles registered to the property owner or lessee of any dwelling located on the property.
GARAGE SALE:	A temporary use allowed in "R" Districts and the RLB-1 District. Garage sales are for the sale of personal items by householders. They are limited to no more than three (3) days of duration and no household may have more than two (2) per year.
GASOLINE SERVICE STATION:	Any building or premises used for retail sale of liquified petroleum products or other fuels for the propulsion of motor vehicles, and including such products as kerosene, fuel oil, packaged naphtha, lubricants, tires, batteries, anti-freeze, motor vehicle accessories, other items customarily associated with the sale of such products; for the rendering of services and making adjustments and small parts replacement to motor vehicles, washing, waxing and polishing of motor vehicles as part of the services rendered; and for making minor repairs to motor vehicles. Repairs of a major type not included are defined to be spray painting, body fender, clutch, transmission, differential, axles, spring and frame repairs; major overhauling of engines requiring the removal of engine cylinder head or crankcase pan; repairs to radiators requiring the removal thereof, or complete recapping or retreading of tires.

**GROUP CARE FACILITY:** An establishment that provides room and board to persons who are residents by virtue of receiving supervised specialized services limited to health, social, rehabilitative or housing services provided by a governmental agency, their licensed or certified agents or other responsible non-profit social service corporation. Supervision shall be provided by at least two responsible adults on duty on the premises on a 24-hour-a-day basis. The residents of the facility need not be related to each other. (Please also see Family.)

**GROUP RESIDENCE FACILITY:** An establishment that provides room and board to persons who are residents by virtue of receiving supervised specialized services limited to health, social, rehabilitative or housing services provided by a governmental agency, their licensed/certified agents or other responsible non-profit social service corporation. These services shall be provided in a family environment and only to persons who are dependent children physically or mentally handicapped, under 18 years of age or elderly, 62 or more years of age not including facilities for the care or treatment of persons released from or under the jurisdiction of a government bureau of corrections or similar institution. The residents of the facility need not be related to each other. If a residence facility qualifies as a family, under this Ordinance, it is not governed by the restrictions in this definition. (Please also see Family.)

**HEAVY MANUFACTURING** The assembly, fabrication, manufacture, processing, production, storage, and/or wholesale distribution of goods or products including but not limited to; cement products, customer sheet metal, patterns, plastic moldings, extrusions and the formulation of basic plastic material, brick and clay products, animal slaughter, curing and rendering, foundries, fuel processing.

**HEIGHT OF STRUCTURE :** The vertical height measured from the elevation of the curb to the highest point of the coping of a flat roof, or to the deck line of a mansard roof, or to the average height of a gabled roof.

**HEIGHT OF A COMMUNICATIONS TOWER:** The vertical distance measured from the ground level to the highest point on a communications tower, including antennas mounted on the tower.

**HISTORIC RESOURCES  
INVENTORY:**

An official list, appropriately documented, of identified historic resources and historic districts in the City, numerically keyed to the Historic Resources Map.

**HISTORIC RESOURCES MAP:**

A map showing some or all of the historic resources of the City of Erie. Said map to be kept on file by the Zoning Officer.

**HOME OCCUPATION:**

A commercial or commercial activity administered or conducted as an accessory use which is clearly secondary to the use as a residential dwelling and which involves no customer, client or patient traffic, whether vehicular or pedestrian, pickup, delivery or removal functions to or from the premises, in excess of those normally associated with residential use. The commercial or commercial activity must satisfy the following requirements: (a) the commercial activity shall be compatible with the residential use of the property and surrounding residential uses, (b) the commercial shall have no employees, (c) there shall be no display or sale of retail goods and no stockpiling or inventory of a substantial nature, (d) there shall be no outside appearance of a commercial use, including, but not limited to, parking, signs or lights, (e) The commercial activity may not use any equipment or process which creates noise, vibration, glare, fumes, odors or electrical or electronic interference, (f) The commercial activity shall be conducted only within the dwelling and may not occupy more than 25% of the habitable floor area. (g) The business may not involve any illegal activity.

**HOTEL-MOTEL:**

A building containing sleeping rooms principally for the use of transients and sometime containing accessory uses, such as kitchen and dining facilities, lounge, meeting rooms, and convention facilities and other commercial uses permitted within the use district.

**IDENTIFICATION SIGN:**

Signs advertising the occupant's business, industry, or products made or sold on the premises and located on the same lot as the business or industry.

**IDENTIFIED HISTORIC  
RESOURCES:**

Any man-made or natural feature identified and documented, including any resource falling within the definition of the

National Register of Historic Places for site, object, building, structure, landscape feature, and related groups thereof, and which is delineated on the City's Historic Resources Map.

LICENSED MASSAGE  
THERAPIST

Any person providing Massage Services in compliance with PA Massage Therapy Law, House Bill 2499 who (a) has earned a degree or certificate with a minimum of 600 hours completed curriculum from a school licensed to teach therapeutic massage techniques, or (b) existing practitioners prior to October 2010 who are eligible for licensure under the Grandfather Provisions of the Massage Therapy Law or (c) is working under the supervision of a licensed physician, licensed nurse, licensed chiropractor, licensed physical therapist or licensed trainer. (8/09)

LIGHT MANUFACTURING:

The assembly, fabrication, manufacture, processing, production, storage, and/or wholesale distribution of goods or products where no process involved will produce noise, vibration, air pollution, fire hazard, or other emissions noxious or dangerous to neighboring including, but not limited to freezer lockers and cold storage, laboratories, commercial laundries, light machine shops, packing and crating service, research laboratories with pilot plants, taxidermists, and commercial welding..

LOT:

A parcel of land abutting on a public street.

LOT AREA

The total area within the lot lines of a lot expressed in either square feet or acres. Any portion of a lot included in a street right-of-way shall not be included in calculating lot area.

LOT, CORNER:

A lot abutting two (2) or more streets at their intersections.

LOT, COVERAGE

That percentage of the lot area which may be covered by all buildings and other areas which may have a roof. Ie porches, decks, pavilions, etc.

LOT, DEPTH:

The mean horizontal distance between the front and rear lot lines.

LOT, DOUBLE FRONTAGE:

A lot having frontage on two (2) non-intersecting streets, as distinguished from a corner lot.

LOT, INTERIOR:

A lot other than a corner lot.

**LOT OF RECORD:** The last recording of a lot in the Office of Recorder of Deeds of Erie County prior to the adoption of this amendment to the Zoning Ordinance.

**LOT, WIDTH:** The width of a lot measured at the minimum building-line and parallel to the street.

**MASSAGE PARLOR:** An enclosed building with floor plans which conform to the requirements of 68 Pa. C.S.A. 5501 et seq. or enclosed area within a building in which the one of the services offered or provided to the patrons, of said enclosed building or enclosed area within a building, consists of body massages, body rubs or other physical manipulation of the patrons body.

Exemptions - this definition shall not apply to physicians, surgeons, chiropractors, osteopaths or physical therapists who are duly licensed to practice their professions in the State of Pennsylvania or those working under the supervision of such persons. In addition, those trained for massage or physical therapy with documentation relative to their training, degree or certification may also be exempted.

**MOBILE /MANUFACTURED HOME**

A self-contained living unit delivered to a lot, and the home is installed upon and securely fastened to a frost free foundation and meets all applicable Codes and Ordinances of the City of Erie pertaining to structures or buildings.

**MUNICIPALITIES PLANNING CODE**

The Pennsylvania Municipalities Planning Code, Act 247 of 1968 as amended

**NATIONAL REGISTER HISTORIC DISTRICT:**

An area of any size which has been designated as a National Register Historic District pursuant to the requirements of the National Park Service.

**NATIONAL REGISTER OF HISTORIC PLACES:**

A federal list of cultural resources worthy of preservation, authorized under the National Historic Preservation Act of 1966 as part of a national program to coordinate and support public and private efforts to identify, evaluate, and protect the nation's historic and archaeological resources.



NEIGHBORHOOD CENTER	A building used for recreational, social, educational and cultural activities owned and/or operated by a public or nonprofit group or agency.
NONCONFORMING LOT	A lot of record that existed with a lawful lot area or lot width or depth prior to the adoption date of this Ordinance or amendment, but which lot area, width or depth fails to conform with the current required minimum lot area and/or lot width or depth.
NONCONFORMING STRUCTURE	A structure, or part of a structure that does not comply with the applicable yard or other dimensional or bulk provisions in this Ordinance as amended, where such a structure lawfully existed prior to the enactment of this Ordinance or amendment. Such nonconforming structures include, but are not limited to nonconforming signs.
NONCONFORMING USE	A use, whether of land or of a structure, which does not comply with the applicable use provisions in this Ordinance or amendment, where such use was lawfully in existence prior to the enactment of this Ordinance or amendment.
NURSING HOME	A facility licensed by the State of Pennsylvania as a “Nursing Home” and which provides residential accommodations and health care to persons who, by reason or advanced age, chronic illness, accident or infirmity, are unable to care for themselves. This term does not include Drug and Alcohol Rehabilitation facilities.
OFF-STREET PARKING LOT:	Any area arranged, designed, used or intended for use for the parking of five (5) or more motor vehicles.
OUTDOOR ADVERTISING:	Any sign that is not an identification sign.
PERSONAL SERVICES:	Any commercial establishment providing services pertaining to the person, his apparel or personal and effects commonly carried on or about the person and including automatic teller machines (excluding drive-in facility), shoe repair, tailoring, and clothes cleaning on the premises brought to the establishment by the customer. Massage Parlors or Adult Uses shall not be considered Personal Services.

PHMC:	The Pennsylvania Historical and Museum Commission.
PLACE OF WORSHIP	A building or group of buildings including customary accessory buildings designed or intended for public worship. For the purpose of this Ordinance, “Place of Worship” includes churches, chapels, cathedrals, temples, mosques and similar designations as well as accessory residential uses.
POOL OR BILLIARD HALL:	An enclosed building or enclosed area within a building the principal use, activity, or recreation conducted and/or provided to the patrons therein being the use, rental or hire of pool tables and related equipment.
PORCH:	A permanently covered entrance to a building.
PORCH, OPEN	A structure, either roofed or un-roofed, open on 3 sides and having no enclosed features of glass, wood or other material more than 42 inches above the floor, except for transparent mesh screening and necessary roof supports.
PORTABLE SIGN	A sign that can be moved from place to place and which is not permanently located, or anchored in the ground or permanently attached to a building.
PRINCIPAL USE:	That use or purpose for which a building, structure, and/or land or major portion thereof, is designed, arranged, or intended, or for which it may be occupied or maintained under the Zoning Ordinance. The use of any minor portion of the building or structure or other building, structure and/or land on the same lot and incident, subordinate, or supplementary thereto and permitted under the Zoning Ordinance shall be considered an accessory use.
PRIVATE CLUB	A building to house a club or social organization which is not an adjunct to or operated by or in connection with a public tavern, café, or other public place. Such establishment must provide the following documentation prior to the issuance of a building permit: (1) Permanency of membership (2) Substantiality of dues (3) Numerical limit on membership (4) Formality of admission procedure (5) Standards for admission (6) Membership control over operation of the organization (7) Club’s purposes (8) use of club facilities by non-members; and (9) history of the organization.

PROFESSIONAL SERVICES:	Any office of establishment providing specialized services to the community in the commonly recognized professions (education, engineering, law, medicine, philosophy, science, theology), the arts (architecture, drama, music, painting, photography, writing), and similar activities (insurance, real estate, etc.).
PUBLIC USES:	Schools, parks, playgrounds, administrative, cultural, institutional and service buildings operated by a government agency but not including public land or buildings devoted primarily or solely to the storage or maintenance of equipment or material.
PUBLIC UTILITY TRANSMISSION TOWER:	A structure, owned and operated by a public utility electric company regulated by the Pennsylvania Public Utility Commission, designed and used to support overhead electricity transmission lines.
RECONSTRUCTION:	Any or all work needed to remake or rebuild all or a part of any identified historic resource to a sound condition, but not necessarily of original materials.
RELATIVE	A spouse, parent, guardian, child, grandparent, grandchild, great grandparent, great grandchild, stepparent, stepchild, stepbrother, stepsister, brother, sister, half brother, half sister, aunt, uncle niece, nephew.
REPAIRS:	Any or all work involving the replacement of existing work with equivalent material for the purpose of maintenance, but not including any addition, change, or modification in construction.
RESIDENTIAL DISTRICT	The R-1, R-1A, R-2, R-3 and RLB Zoning Districts
RESTORATION:	Any or all work connected with returning or restoring an identified historic resource or a part of any identified historic resource to its original (or nearly original) condition through the use of original or nearly original and compatible materials.
RETAIL USE	An establishment engaged in selling goods or merchandise to the general public for personal or household consumption and

rendering services incidental to the sale of such goods. A retail store may include the creations of Baked goods, candy, custom crafts, such as jewelry or leather items as an accessory use.

**ROOMING/BOARDING HOMES:** A building or part thereof, other than a hotel or restaurant where meals and/or lodging are provided, for compensation for more than three (3) or more persons not transients.

**SCRAP YARDS:** A place where waste, discarded or salvaged materials are bought, sold, exchanged, stored, baled, cleaned, packed, disassembled or handled, including auto wrecking yards, house wrecking yards, used lumber yards, and places for yards for use of salvaged house wrecking and structural steel materials and equipment, but excluding such uses when conducted entirely within a completely enclosed building and excluding pawn shops and establishments for the sale, purchase or storage of used cars in operable condition, salvaged machinery, used furniture and household equipment, and the processing of used, discarded or salvaged material as part of manufacturing operations.

**SCREENING:** Screening shall mean a fence, evergreen hedge or wall at least six (6) feet high, provided in such a way that it will block a line of sight. If an evergreen hedge is planted, the hedge must reach six feet in height within one year of planting. Screening shall be maintained and kept clean of debris, rubbish and weeds

**SECRETARY OF THE  
INTERIOR'S STANDARDS FOR  
REHABILITATION AND  
GUIDELINES FOR  
REHABILITATING HISTORIC  
BUILDINGS:**

A federal document stating standards and guidelines for the appropriate rehabilitation and preservation of historic buildings.

**SEMI-PUBLIC USES:** Churches, Sunday schools, parochial schools, colleges, hospitals, and other institutions of an educational, religious, charitable or philanthropic nature.

**SERVICE GARAGE** A facility where repairs to the frame or other structural parts of motor vehicles, spray painting, and repair or

replacement of fenders and similar external portions of motor vehicles are conducted. An auto body shop may also include Auto Sales of not more than four (4) vehicles, conditioned upon the fact that all Off Street Parking requirements are met.

**SETBACK LINE**

The line beyond which structures may not be erected.

**SMALL WIND ENERGY SYSTEMS:**

A wind energy conversion system consisting of a wind turbine, a tower, and associated control and conversion electronics which has a rated capacity of not more than one hundred (1 00) kilowatts (kW) and which is. designed and used to generate power solely to serve to offset utility costs of a principal and/or accessory building located on the lot on which said device is situated.

**SOLID WASTE TRANSFER FACILITY**

Land and/or structures where solid waste is received and temporarily stored at a location other than the site where the waste was generated, and which facilitates the bulk transfer of accumulated solid waste to a different site for disposal. A Transfer-Facility may also include separation and/or processing of recyclables.

**SOLAR COLLECTION SYSTEM:**

A panel or other solar energy device, the primary purpose of which is to provide for the collection, inversion, storage, and distribution of solar energy for electricity generation, space heating, space cooling or water heating.

**SPECIFIED ANATOMICAL AREAS:**

1. Less than completely and opaquely covered:  
(a) human genitals, pubic region, (b) buttock, and (c) female breast below a point immediately above the top of the areola; and
2. Human male genitals in a discernibly turgid state, even if completely and opaquely covered.

**SPECIFIED SEXUAL ACTIVITIES:**

1. Human genitals in a state of sexual stimulation or arousal;
2. Acts of human masturbation, sexual intercourse or sodomy;

3. Fondling or other erotic touching of human genitals, pubic region, buttock or female breast.

**SPECIAL EXCEPTION**

A use which by virtue of its own peculiar characteristics may be permitted in certain areas only after review, hearing and approval by the Zoning Hearing Board.

**STRUCTURE:**

Anything constructed or erected, the use of which requires a fixed location on the ground or an attachment to something having a fixed location on the ground, including, in addition to buildings, billboards, carports, porches, swimming pools, and other building features but not including sidewalks, drives, fences and porches without a roof or enclosed sides.

**SUPPLY YARDS:**

A commercial establishment storing or offering for sale building supplies, steel supplies, coal, heavy equipment, feed and grain, and similar goods. Supply yards do not include the wrecking, salvaging, dismantling or storage of automobiles and similar vehicles.

**TRUCKING TERMINAL**

An area and building where materials are stored and where trucks load and unload materials on a regular basis, including the incidental servicing of trucks.

**TOWNHOUSE(S):**

A one-family dwelling in a row of at least three (3) such units in which each unit has its own front and rear access to the outside, no unit is located over another unit and each unit is separated from another unit by a common wall.

**FEE SIMPLE TOWNHOUSE**

Is a Townhouse where side yard setbacks are forgiven for the individual sale of each. Side yard setbacks will be enforceable on end units.

**TRANSIENT:**

Any individual residing or stopping in a city for less than thirty (30) days at any one time.

**TURBINE HEIGHT:**

A wind energy conversion system consisting of a wind turbine, a tower, and associated control and conversion electronics which has a rated capacity of not more than one hundred (1 00) kilowatts (kW) and which is designed and used to generate power solely to serve to offset utility costs of a principal and/or accessory building located on the lot on which said device is situated.

URBAN SOLAR FARM:	Energy generation facility or area of land principally used to convert solar energy to electricity.
USE	The specific purpose for which land or a building is designed, arranged, intended or for which it is or may be occupied or maintained.
VARIANCE	A means of seeking relief from the requirements of this ordinance. The Zoning Hearing Board has the exclusive authority to vary the terms of this ordinance.
WAREHOUSE	A building designed for the storage of personal or commercial goods and materials.
WATERFRONT DISTRICT	Shall include the W-R, W-C, W-C2, W-C3, and W-M Districts
WHOLESALE DISTRIBUTION CENTER	A commercial dealing in the sale of items in large quantities. Retail sale of items is permitted as an accessory use up to 20% of the total floor area.
WIND ENERGY CONVERSION SYSTEM:	Any device such as a wind charger, wind turbine or Windmill and/or other electric generation facility whose main purpose is to convert wind power into another form of energy such as electricity or heat for distribution, consisting of one or more wind turbines and other accessory structures and buildings, including substations, meteorological towers, electrical infrastructure, transmission lines and other appurtenant structures and facilities
WIND TURBINE:	A wind energy system that converts wind energy into electricity through the use of a wind turbine generator, and includes the nacelle, rotor, tower and pad transformer, if any.
YARD, FRONT:	An open, unoccupied space across the full width of the lot, extending from the front line of the building to the front property line of the lot.
YARD, REAR:	An open, unoccupied space across the full width of the lot extending from the rear line of the building to the rear property line of the lot.

YARD, SIDE:	An open, unoccupied space extending from the front yard to the rear yard line between a building and the nearest side of the lot.
ZONING HEARING BOARD	The Zoning Hearing Board of the City of Erie as appointed by the governing body.
ZONING OFFICER	The Zoning Administrator and any assistants authorized to administer and enforce the Ordinance



## **ARTICLE 7 - HISTORIC RESOURCES PROTECTION**

**701 STATEMENT OF INTENT:** The intent of this Article is to provide a comprehensive framework for the preservation of historic sites, objects, buildings, structures, and districts in the City of Erie, as provided by Article VI of the Pennsylvania Municipalities Planning Code. It is the further intent of this Article to support the purposes of Article 1, §27 of the Constitution of the Commonwealth of Pennsylvania.

**702 OVERVIEW OF PROVISIONS:** This Article provides for a Historic Overlay District (or Districts), for the City of Erie, which affects historic resources. Identified historic resources include, but are not necessarily limited to, historic structures, buildings, objects, or sites. This district(s) is (are) shown on the City of Erie Zoning Map as the Historic Overlay (HO) District. Owners of structures in the Historic Overlay District must comply with the provisions of this Article, as well as the provisions of the underlying zoning district.

**703 ZONING OVERLAY CONCEPT:** The “Zoning Map, City of Erie, Pennsylvania” may be amended to show one or more Historic Overlay Districts. An overlay zone may encompass one or more underlying zoning districts and imposes additional requirements above that required by the underlying zone. The HO District is designed for the purposes of historic preservation.

A. Historic Resources Map shall be kept on file at the office of the Zoning Officers. This map will be based upon comprehensive surveys and inventories of historic/cultural resources. The map may contain all, or portions, of the City. No request for a Historic Overlay District will be allowed until the necessary survey and inventory have been completed for the area in question. If the area under consideration does not appear on the Historic Resources Map, it shall be the obligation of the proposer(s) to present the necessary documentation, including a Historic Resources Inventory. The Zoning Officer shall consult with the Design Review Committee and other appropriate organizations to verify that the information presented is accurate, authentic and appropriate for the requested designation.

B. Notice. Notice will be given to all owners of properties classified as Identified Historic Resources, when their property is to be included in the HO District.

C. Revisions. The Historic Resources Map may be revised or amended from time to time by action of the City.

D. In considering the preparation of, or any revision, including additions, deletions, or changes to a Historic Resources map, the City may request a written recommendation from the Erie County Historical Society.

**704 IDENTIFIED HISTORIC RESOURCES:** Determination of the City's Identified Historic Resources shall be made by the City of Erie in accordance with:

Historic Resources Inventory. The City shall maintain an inventory of Identified Historic Resources shown on the Historic Resources Map, and shall update such inventory at such time(s) as the City revises the Historic Resources Map in accordance with this Article.

Compliance. Any change or alteration of to a historic resource in the HO District shall occur only in full compliance with the terms of this Article.

Should the Historic Overlay District be revised as a result of legislative or administrative action or a judicial decision, the zoning requirements and other regulatory measures applicable to any properties deleted therefrom shall be those of the underlying zoning district without consideration of this Article.

**705 PROVISIONS WHICH APPLY TO ALL STRUCTURES EXISTING OR PROPOSED WITHIN THE HISTORIC OVERLAY DISTRICT:**

1. Changes to Identified Historic Resources.

1. Alterations, modifications, removal, or demolition of Identified Historic Resources in on the Historic Overlay District shall not be approved nor a building permit issued until such action has been reviewed by the Zoning Officer.

2. The Design Review Committee shall advise the Zoning Officer on matters relating to applications in the HO District. The Committee shall have twenty-one (21) days to make its recommendations from the date the Zoning Officer forwards a copy of such application(s) required under this Article.

3. The provisions of this Article shall not be construed to prevent the ordinary maintenance or repair of any building, structure, site, or object where such work does not require a permit and where the purpose and effect of such work is to correct any deterioration or decay of, or damage to, a building, structure, site, or object and to restore the same to its condition prior to the occurrence of such deterioration, decay, or damage.

4. No building, site, structure, or object located in whole or in part within the Historic Overlay District shall be erected, and the Zoning Officer shall issue no permit for such action, until a permit is obtained from the City. The City shall pass upon the appropriateness of exterior architectural features only where they can be seen from a public street or way, and shall consider the general design, arrangement, texture, material and color of the building or structure and the relation of such factors to similar features of buildings and structures in the district.

## **706 APPLICATION PROCEDURES:**

### 1. Application for Permit.

1. The application for a permit required to obtain a building, or other permit, or as required before exterior alteration to any building or structure located within a Historic Overlay District may begin, shall be filed with the Zoning Officer, together with the required filing fee.

#### 1. The application shall include:

- (1) a site plan at a scale of one (1) inch to forty (40) feet;
- (2) schematic architectural drawings of the proposed construction or changes, at a scale of one (1) foot to one quarter (1/4) inch; and
- (3) elevations drawn to scale showing alterations as seen from public right-of-ways; and
- (4) a certification by an architect that the construction, alteration, modification, or rehabilitation proposed by the application is consistent with Section 706 of this Article.

2. Standards of Appropriateness. The standards to be used by the City in determining the appropriateness of any proposed action shall be those contained in §707 of this Article.

## **707 STANDARDS AND CONSIDERATIONS FOR ARCHITECTURAL REVIEW:**

A. Rehabilitation Standards. The Secretary of Interior's *Standards for Rehabilitation*, presented in this Subsection, should guide any applicant for a building permit and will be considered by the City in the review of such application.

1. A property shall be used for its current purpose or be placed in a new use consistent with the underlying district.
2. The historic character of the property shall be retained and preserved. The removal of historic materials or alterations of features and spaces that characterize a property shall be avoided.
3. Each property shall be recognized as a physical record of its time, place, and use. Changes that create a false sense of historical development, such as adding conjunctural features or architectural elements from other buildings, shall not be undertaken.

4. Most properties change over time; those changes that have acquired historic significance in their own right shall be retained and preserved.
5. Distinctive features, finishes, and construction techniques or examples of craftsmanship that characterize a historic property shall be preserved.
6. Deteriorated historic features shall be repaired rather than replaced. Where the severity of deterioration requires replacement of a distinctive feature, the new feature shall match the old in design, color, texture, and other visual qualities and, where possible, materials. Replacement of missing features shall be substantiated by documentary, physical, or pictorial evidence.
7. Chemical or physical treatments, such as sandblasting, that cause damage to historic materials shall not be used. The surface cleaning of structures, if appropriate, shall be undertaken using the gentlest means possible.
8. New materials, exterior alterations, or related construction shall not destroy historic materials that characterize the property. The new work shall be differentiated from the old and shall be compatible with the massing, size, scale, and architectural features to protect the historic integrity of the property and its environment.
9. New additions and adjacent or related new construction shall be undertaken in such a manner that, if removed in the future, the essential form and integrity of the historic property and its environment would be unimpaired.

B. Consideration for Design Review. Among the criteria used in evaluating any proposed reconstruction, alteration, or restoration of an Identified Historic Resource, or construction of a new building, structure, or object, the City shall consider the following, where relevant:

1. Mass (height, bulk, nature of roof line)
2. Proportions (height to width)
3. Consistency with architectural style with nearby structures within the HO District.
4. Nature of yard space
5. Extent of landscaped areas versus paved areas
6. The nature of facade opening (doors and windows), including size, locations, and proportions
7. Type of roof (flat, gabled, hip, gambrel, mansard, etc.)

8. Nature of projections (porches, etc.)
9. Nature of the architectural details and style
10. Nature of the materials
11. Color
12. Texture
13. Ornamentation
14. Signs

## **708 VIOLATIONS, PENALTIES, AND ENFORCEMENT**

- A. Violations and Penalties. Any person who violates the terms of this Article shall be subject to the fines and penalties imposed by this Ordinance.

# TYPICAL PLOT PLAN

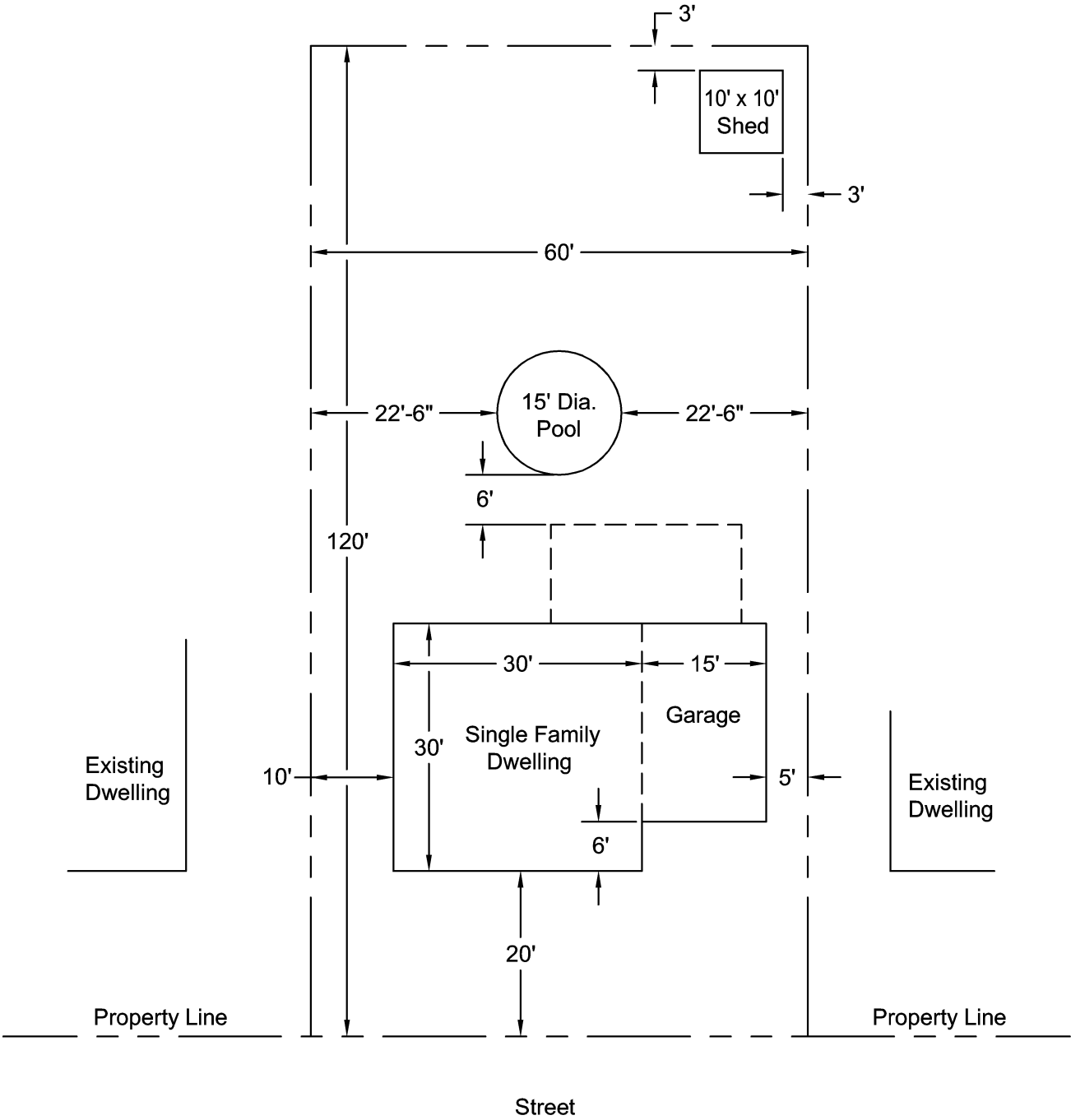

Illustration No. 1

# TYPICAL PARKING LOT LAYOUT

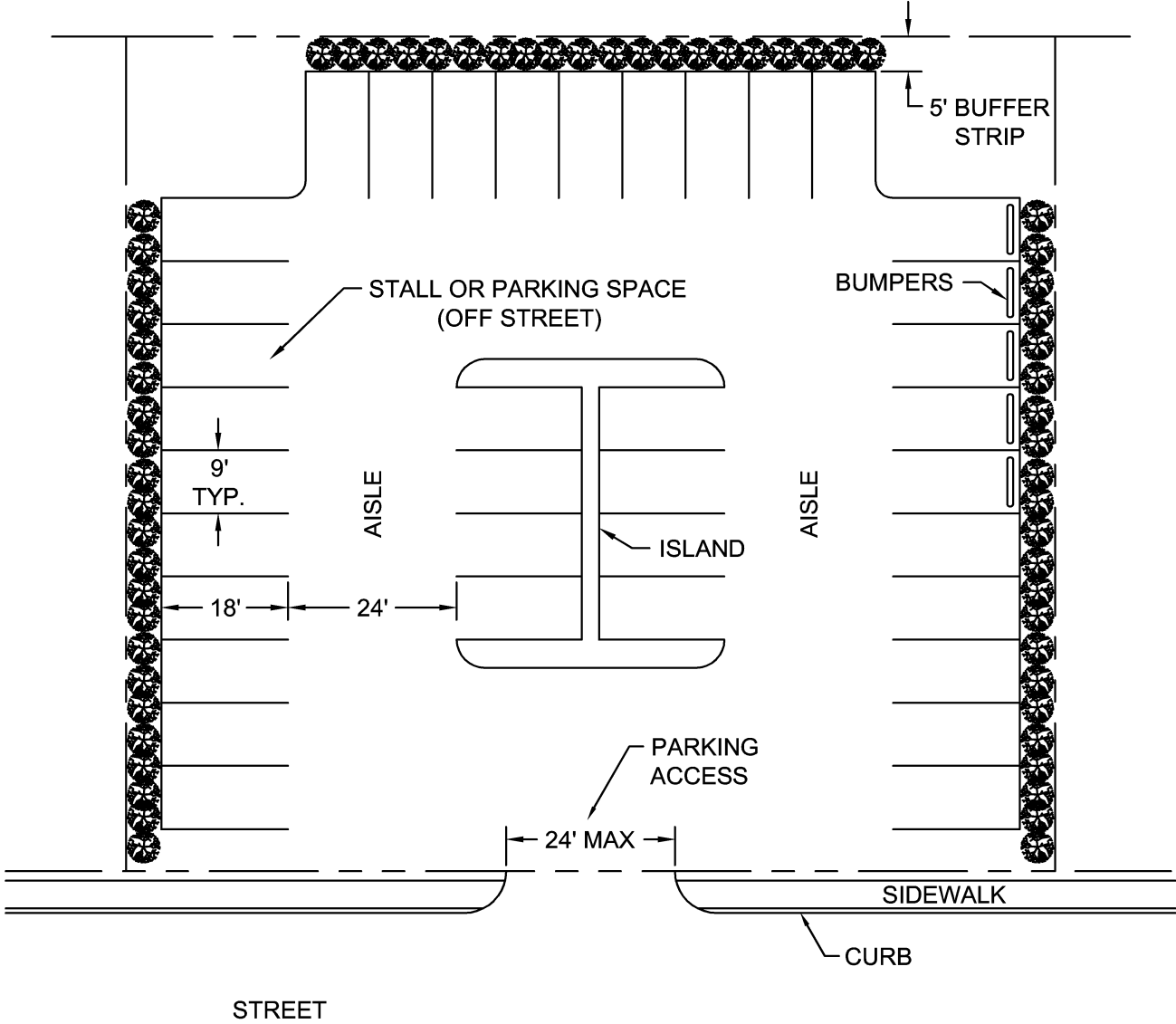
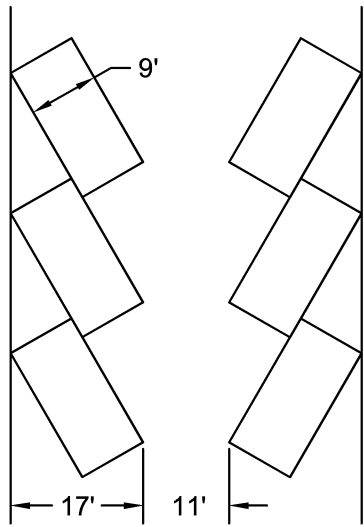

Illustration No. 2

# Parking Area Dimensions

## TYPICAL PARKING LOT DESIGNS



**30 Degree Parking**

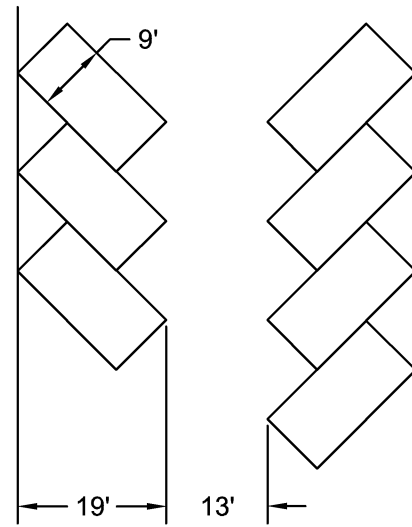

**45 Degree Parking**

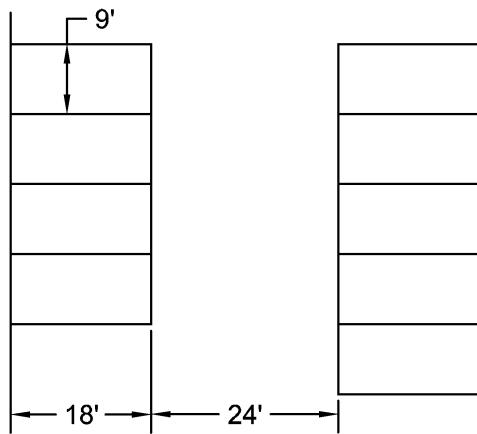

**Perpendicular  
90 Degree Parking**

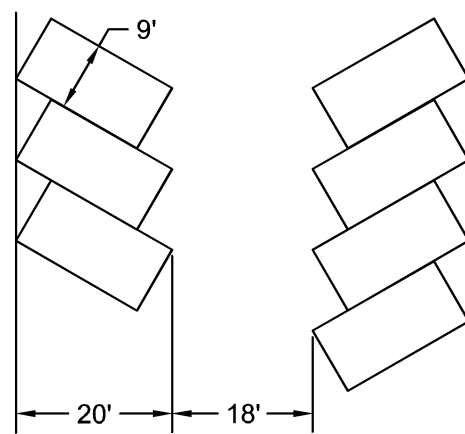

**60 Degree Parking**

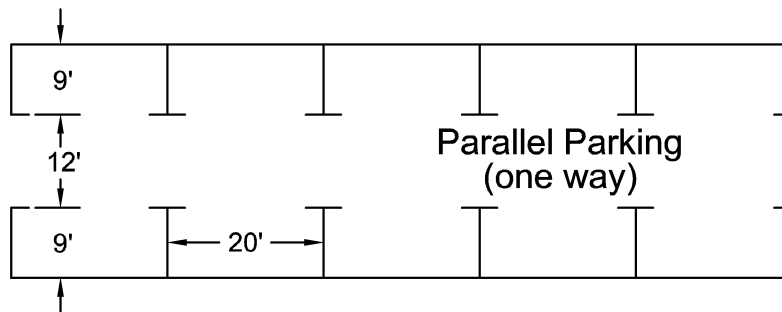



# HEIGHT OF BUILDINGS

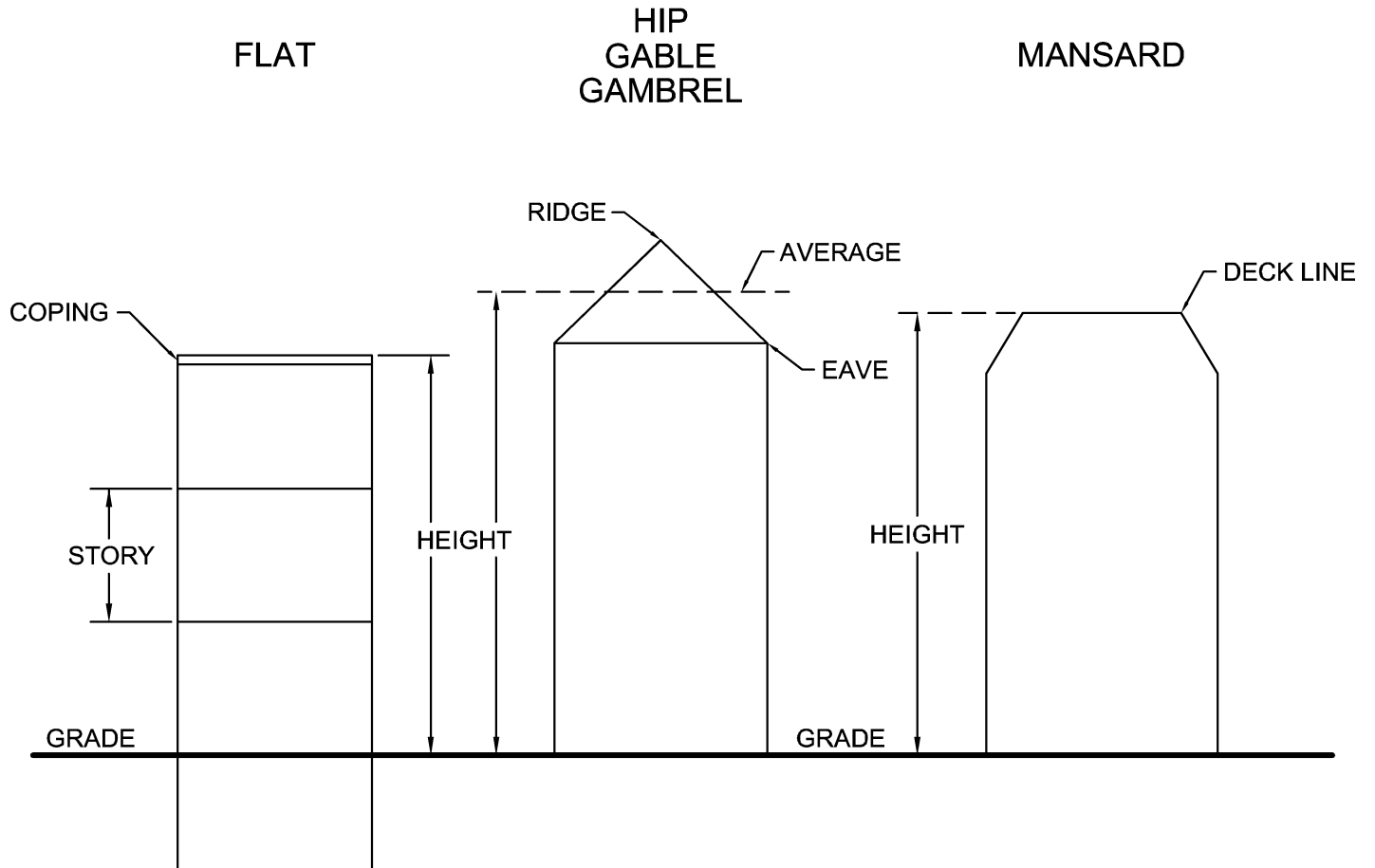

Illustration No. 4

# FENCE DETAIL

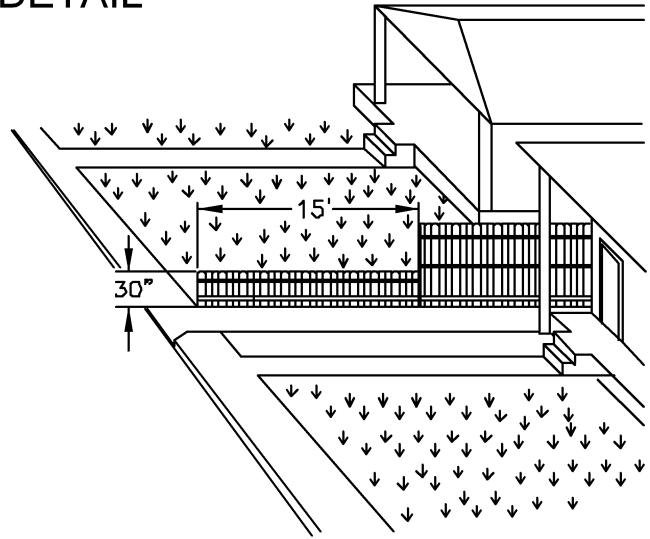
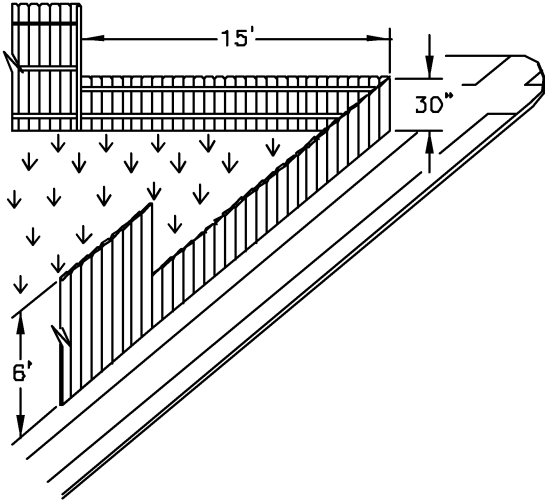

Illustration No. 5